

URBAN POOLS

6.00 M X 2.50 M

with integrated automatic cover

INSTALLATION AND OPERATING INSTRUCTIONS

(to be read carefully and kept for future reference)

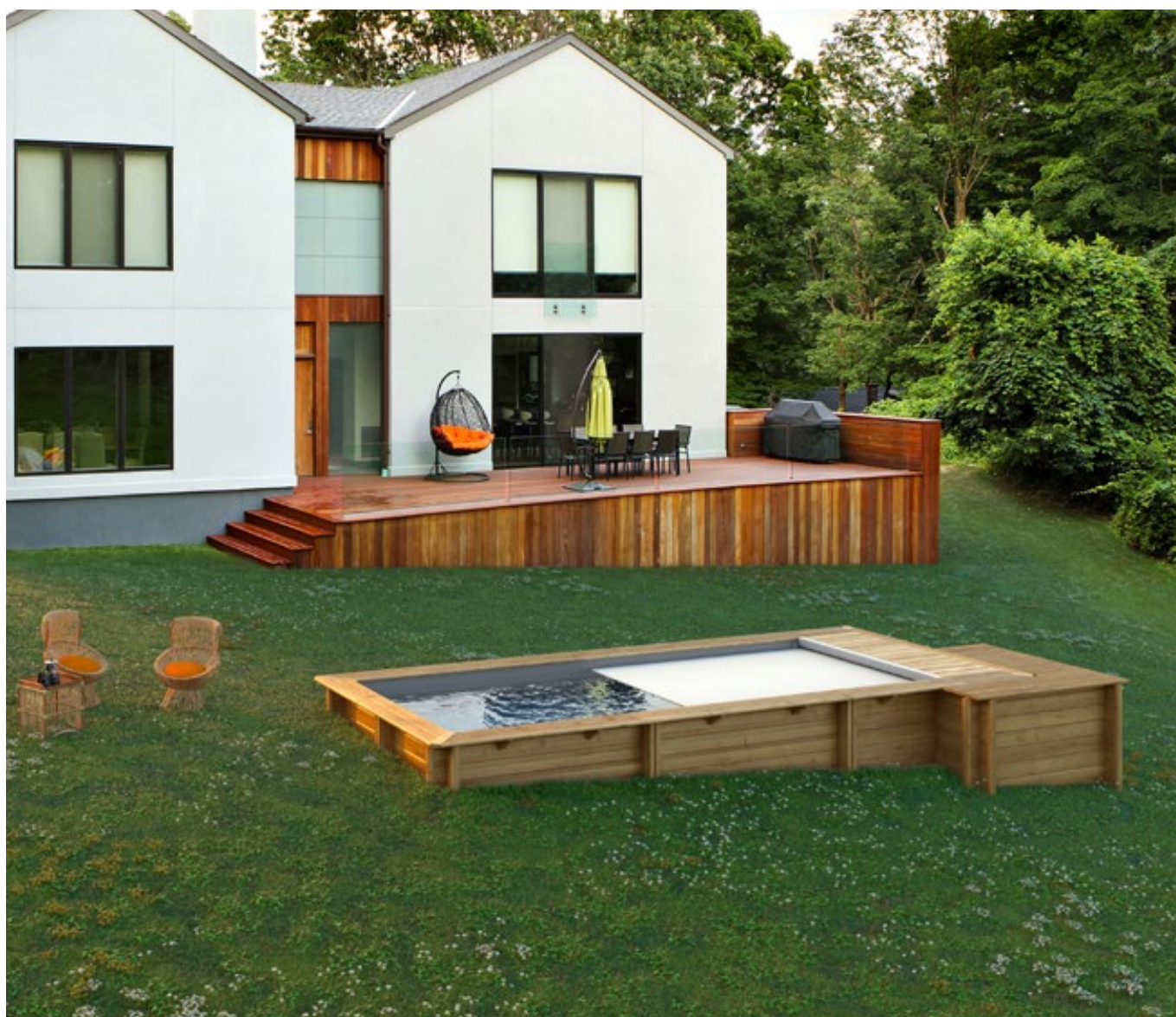

URBAN POOLS

GB Page 1

1. PRESENTATION	5
2. FOREWORD	5
2.1 Storage	5
2.2 An above-ground kit.....	5
2.3 Safety	5
2.4 Assembly	6
2.4.1 Assembly steps.....	6
2.4.2 Tools.....	6
2.4.3 Assembly time.....	6
2.5 Nomenclature.....	7
2.5.1 Wood and coping pack	7
2.5.2 Automatic cover pack.....	10
3. WOOD, A NATURAL MATERIAL	11
3.1 Colour variations	11
3.2 Resin beads	11
3.3 Salt stains	11
3.4 Greying	12
3.5 Splitting and cracking.....	12
3.6 Knots.....	12
3.7 Surface mould.....	13
3.8 Joined wood.....	13
4. EARTHWORKS	14
4.1 Introduction	14
4.2 Creating the excavation	14
4.2.1 Material quantities.....	14
4.2.2 Excavation	14
4.2.3 Drainage	14
4.2.4 Stone bedding.....	15
4.3 Installing the supporting braces	16
4.4 Pouring the concrete slab	18
4.4.1 Rebar	18
4.4.2 Slab dimensions.....	18
5. ASSEMBLING THE WOODEN STRUCTURE	20
5.1 Introduction	20
5.2 Application of the bituminous strips	22
5.3 Assembling the slats	22
5.4 Mounting the finishing trim on the supporting braces	24
5.5 Fitting the supporting brace pinch sockets	24
5.6 Mounting the coping brackets.....	25
5.7 Assembling the wooden access ladder	26
5.8 Mounting the metal fittings	27
5.9 Finishing trim.....	27
6. INSTALLATION OF THE FILTRATION SYSTEM	28
6.1 ABS fittings	28
6.1.1 Skimmer.....	28
6.1.2 Return fitting body.....	29
6.2 PVC pipework for filtration	29

7. PARTS FOR THE AUTOMATIC COVER	31
7.1 Throughwall flange	31
7.2 Bearing mounting unit.....	32
8. IN-POOL LADDER.....	33
8.1 Assembling the in-pool ladder	33
8.2 Drilling holes to mount the ladder	33
9. FITTING THE WATERPROOFING MEMBRANE	34
9.1 Installing the liner locking track	34
9.2 Drilling for the beam mounting unit	34
9.3 Applying self-adhesive gaskets	35
9.4 Fitting the underlay	35
9.5 Fitting the liner	35
9.6 Underwater light cable ties	36
9.7 Installing flanges on pool fittings	37
9.7.1 Return fitting flange.....	37
9.7.2 Throughwall fitting flange.....	38
9.7.3 Bearing mounting unit flange	38
9.7.4 Skimmer flange	38
9.8 Installation of the ladder rails	39
10. ASSEMBLY OF THE AUTOMATIC COVER	40
10.1 ASSEMBLY OF THE AUTOMATIC COVER	40
10.1.1 Installation of the stainless steel shaft	40
10.1.2 Fitting the axle into the bearing mounting unit.....	40
10.1.3 Fitting the automatic cover shaft into the axle.....	40
10.2 Beam and beam flanges.....	41
10.3 Installing the pit wall and the underwater light	42
10.4 Automatic cover apron and safety fasteners	43
10.4.1 Advice prior to installation.....	43
10.4.2 Assembling the slat cover.....	43
10.4.3 Locking the slats in position.....	43
10.4.4 Installing the cover apron safety fastener	44
10.4.5 Securing and releasing the slat cover	45
10.5 Water level in the pool for correct operation of the cover	45
11. INSTALLATION OF THE COPING AND FINISHING ELEMENTS	46
11.1 Cartridge and pre-filter	46
11.2 Coping	46
11.3 Duckboarding.....	48
11.4 Ladder hand rail	49
11.5 Static swim belt.....	49

12. WIRING	50
12.1 Automatic cover motor	50
12.1.1 Safety advice concerning the motor	50
12.1.2 Assembly of the automatic cover motor	50
12.2 Electrical panel: mounting and wiring	51
12.2.1 Safety advice concerning the electrical panel	51
12.2.2 Mounting the electrical panel on the wall	51
12.2.3 Electrical panel power supply	52
12.2.4 Connecting the filtration pump	52
12.2.5 Connecting the underwater light	52
12.2.6 Connecting the motor	53
12.2.7 Connecting the end of travel sensors	53
12.2.8 Connecting the key switch	53
12.3 Adjusting the ends of travel and anti-tear	53
13. WATER TREATMENT	55
13.1 Maintaining pool water quality	55
13.2 Filtration settings	55
13.2.1 Length of the filtration cycle	55
13.2.2 Setting the filtration timer	56
13.3 Filtration cartridge maintenance	56
13.3.1 Removal and refitting of the cartridge	56
13.3.2 Cleaning the cartridge using a brush and a hose	56
13.3.3 Cleaning the cartridge by soaking	57
13.3.4 Replacement of the cartridge	57
14. SAFETY	57
14.1 Safety of children	57
14.2 Swimming aids	58
14.3 Safety of all users	58
14.4 Safety plate	58
14.5 Safety cover	59
14.6 Filtration pump	59
15. MAINTENANCE OF YOUR URBAN POOL	60
15.1 Maintenance of the pool structure	60
15.2 Maintenance of the filtration pump	60
15.3 Maintenance of the cover	61
15.4 Winterizing the pool	61
16. GUARANTEES	62
16.1 Guarantee covering the wooden components	62
16.2 Guarantee covering accessories	62
16.2.1 Liner guarantees	62
16.2.2 Guarantee covering the standard filtration pump	63
16.2.3 Guarantee covering ABS fittings (skimmer, return fitting)	63

1. PRESENTATION

URBAN pools represent a true innovation: they combine the advantages usually associated with top-end pools, with the practical advantages of more modestly sized pools. Thanks to its small size you can install an URBAN pool wherever you want.

URBAN pools are the answer! A real pool secured by an in-pool automatic cover with a water surface area of less than 10 m² that slips easily into any space

2. FOREWORD

Once you have built your pool, keep the documentation (installation instructions, invoice, etc). You will need these for any future exchanges with our various services.

Great care has gone into the manufacture of your pool, however, some precautions are necessary for its correct assembly and use. We strongly recommend that you read the installation instructions carefully before beginning assembly of the pool, and that you keep them for future reference concerning the use and maintenance of the pool. In the event of any claim, you will need to quote the pool's tracking number that you will find at the end of this document.

2.1 Storage

If you do not intend to assemble your pool immediately, do not unpack the components, store the boxes in a suitable, well ventilated, cool area protected from the sun and bad weather. The purpose is to avoid deformation of the wooden elements that would make assembly more difficult.

Deformation of the wood could only be caused by storing the wood other than as recommended. If you had to unpack your pool, you must repack and restrap the pallet of wooden elements.

Once the wooden elements are unpacked, proceed with assembly within the next 24 to 48 hours. While storing the boxes, we recommend that you remove the film and insert wooden wedges between each layer of wood to facilitate the circulation of air.

2.2 An above-ground kit

The kit delivered is for an above-ground installation. If the pool is to be installed in-ground (or partially in-ground) some extra work and materials will be required:

- acquire the URBAN pool wooden plant housing;
- carry out the necessary excavation work;
- create a drain and a relief well adapted to the terrain around the periphery of the concrete slab;
- cover the in-ground sections of wall with a foundation membrane;
- backfill behind the walls with 10/20 rolled gravel.

The necessary supplies are not included in the kit.

2.3 Safety

Your electrical installation must comply with the standard in effect in the country of installation (C15-100 in France). Notably, the electrical supply of the pump should be protected by a 30mA residual current device. Do not hesitate to have this work carried out by a professional to ensure the compliance of your installation.

The kit provided will allow installation of the filtration system 3.5 m from the pool in accordance with the French safety standard NF C15-100.

Subject to the condition that the cover is mounted according to the installation instructions provided in this document, the safety cover equipping your Urban pool will secure access to the pool in accordance with the French safety standard NF P90 308 (December 2013).

Children should only use the pool under the supervision of an adult. This pool is intended for private use only.

Installation of the pool beneath trees is not advised, installation beneath electrical wires is strictly prohibited.

2.4 Assembly

2.4.1 Assembly steps

- excavation
- assemble the supporting braces
- pour the concrete slab
- assemble the wooden structure
- install the filtration system and pool fittings
- assemble the vertical section of the ladder
- lay the waterproofing membrane
- assemble the automatic cover
- install the coping and finishing trim
- wiring

2.4.2 Tools

Excluding the materials required for excavation and pouring the concrete slab, we recommend that you have the following equipment on hand:

- measuring tools: decameter, rope, big spirit level
- mallet
- drill and drill bits, flat head screw driver, cross head screw driver, drill bit diameter 10 mm
- cutting tools: Stanley knife, metal saw, hole saw diameter 60 mm
- tube or socket wrench (13 and 17mm), set of Allen keys
- finishing tools: sand paper, lime fine
- tools for glueing pipework: medium sand paper, PVC stripper

2.4.3 Assembly time

Excavation and earthworks: **1 TO 2 DAYS DEPENDING ON THE MATERIALS USED**

Supporting braces: **½ DAY (WITH 2 PEOPLE)**

Pouring the slab: **½ DAY (WITH TWO PEOPLE) DEPENDING ON THE MATERIALS USED**

Wooden structure and cover: **1 TO 2 DAYS (WITH TWO PEOPLE - THE TIME INDICATED DOES NOT INCLUDE THE CONCRETE CURING TIME)**

Curing of the concrete slab: **21 DAYS (3 WEEKS)**

2.5 Nomenclature

2.5.1 Wood and coping pack

Wooden elements

QTY	DESCRIPTION	FIGURE	REF	DIMENSIONS (MM)	TYPE
2	Wall slat	<i>Figure 7</i>	no.1	2332 × 78 × 45	Male
32	Wall slat	<i>Figure 7</i>	2	2031 × 145 × 45	Male/female
18	Wall slat	<i>Figure 7</i>	3	1908 × 145 × 45	Male/female
14	Wall slat	<i>Figure 7</i>	4	2332 × 145 × 45	Male/female
1	Wall slat	<i>Figure 7</i>	5	2332 × 145 × 45	Male/female, machined to receive the return fitting
2	Wall slat	<i>Figure 7</i>	no.11	2031 × 145 × 45	Male/female, machined to receive the throughwall flange
2	Wall slat	<i>Figure 7</i>	no.10	2031 × 145 × 45	Male/female, machined to receive the throughwall flange
1	Wall slat	<i>Figure 7</i>	no.6	2332 × 145 × 45	Male/female, machined to receive the skimmer
1	Wall slat	<i>Figure 7</i>	no.7	528 × 137 × 45	Female for the skimmer
1	Wall slat	<i>Figure 7</i>	no.9	1604 × 137 × 45	Female for the skimmer
2	Wall slat	<i>Figure 7</i>	no.12	1908 × 70 × 45	Female
2	Wall slat	<i>Figure 7</i>	no.15	2031 × 70 × 45	Female
2	Wall slat	<i>Figure 7</i>	no.13	2031 × 70 × 45	Female
1	Wall slat	<i>Figure 7</i>	no.14	2332 × 137 × 45	Female
8	Trim	<i>Figure 12</i>	-	1290 × 137 × 45	For supporting braces
2	Supporting brace	<i>Figure 13</i>	-	1285 × 145 × 45	-
17	Coping brackets	<i>Figure 14</i>	-	180 × 150 × 45	-
2	Ladder rail	<i>Figure 16</i>	-	1330 × 95 × 35	-
4	Ladder tread	<i>Figure 16</i>	-	600 × 145 × 27	-
8	Trim	<i>Figure 20</i>	-	1295 × 70 × 45	To finish the corners
1	Cleat	<i>Figure 23</i>	no.8	200 × 25 × 25	For the skimmer
1	Coping module	<i>Figure 51</i>	no.1	1071 × 145 × 28	Interior
1	Coping module	<i>Figure 51</i>	no.2	1071 × 145 × 28	Interior
1	Coping module	<i>Figure 51</i>	no.3	1901 × 145 × 28	Interior
4	Coping module	<i>Figure 51</i>	no.4	1838 × 145 × 28	Interior and Exterior
2	Coping module	<i>Figure 51</i>	no.5	1325 × 145 × 28	Interior
1	Coping module	<i>Figure 51</i>	no.6	626 × 145 × 28	Interior
1	Coping module	<i>Figure 51</i>	no.7	1901 × 145 × 28	Interior
1	Coping module	<i>Figure 51</i>	no.8	626 × 145 × 28	Interior
2	Coping module	<i>Figure 51</i>	no.9	2046 × 145 × 28	Exterior
2	Coping module	<i>Figure 51</i>	no.10	2046 × 145 × 28	Exterior
1	Coping module	<i>Figure 51</i>	no.11	1216 × 145 × 28	Exterior
2	Coping module	<i>Figure 51</i>	no.12	1216 × 145 × 28	Exterior
1	Coping module	<i>Figure 51</i>	no.13	485 × 145 × 28	Exterior, with pivot pin hole
1	Coping module	<i>Figure 51</i>	no.14	396 × 145 × 28	Exterior, with pivot pin hole
1	Coping module	<i>Figure 51</i>	no.15	329 × 145 × 28	Exterior, with pivot pin hole
2	Mitered cleat	<i>Figure 51</i>	no.16	206 × 70 × 28	Corner
2	Mitered cleat	<i>Figure 51</i>	no.17	412 × 70 × 28	Corner
2	Straight cleat	<i>Figure 52</i>	-	735 × 70 × 28	For duckboarding

4	Straight cleat	<i>Figure 52</i>	-	585 × 70 × 28	For duckboarding
13	Duckboarding	<i>Figure 52</i>	-	600 × 145 × 28	-
1	Wall slat	-	-	≈ 290 × 145 × 45	For martyr block

Screws for the pool structure

QTY	DESCRIPTION	KIT	PURPOSE
2	Torx safety screw 6 × 30, A2 SS	Y	Fasten the elastic strap underneath the duckboarding
4	Hex screw M8 × 120, A2 SS, DIN 931	Y	Fasten the beam and counter plate to the polyamide blocks from outside the pool
4	Screw, M8 × 70 DIN 603 A4 (round head, square neck)	Y	Fasten the beam and counter plate from inside the pool
4	Countersunk screws, 4.2 × 19, A4 SS, DIN 7982	Y	Fasten the polyamide blocks to the pit wall flanges
6	Stove screws, M8 × 16, A4 SS torx	Y	Fasten the elastic strap at the bottom of the pit wall modules (x 2) Fasten the pit wall to the beam mounting plate (x 4)
4	Hex screws, M8 × 20, A4 SS, DIN 933	Y	Assembly of the pit wall modules
18	Nut M8, A4 SS, DIN 934	Y	Fasten the pit wall brackets to the beam mounting plates (x 4) Fasten the beam and counterplate from inside the pool (x 4) Assembly of the pit wall modules (x 8) Fasten straps to the pit wall (x2) Fasten the pit wall to the beam mounting plate (x 4)
26	Washer M8, A4 SS, NFE 25-514	Y	Fasten the pit wall brackets to the beam mounting plates (x 4) Fasten the beam and counterplate from inside the pool (x 4) Assembly of the pit wall modules (x 8) Fasten straps to the pit wall (x2) Fasten the pit wall to the beam mounting plate (x 8)
3	Torx bits	J	T20 ; T25 ; T30
1	Wood drill bits 4 × 75 mm	J	Pre-drilling the Hung liner locking track
24	Nut, M10, zinc plated steel	A	Fasten the 3 jacks to each of the four supporting braces
8	Nut, M8, A4 SS, DIN 934	B	Fasten the ladder hand rail to the coping
8	Washer, M8, A4 SS, NFE 25-514	B	Fasten the ladder hand rail to the coping
8	Mushroom head screw, M8x50, A2 SS, ISO 7380	B	Fasten the ladder hand rail to the coping
80	Countersunk screw, 5 × 40 A4 SS, torx, threaded over 25 mm	C	Lock the slats together at the supporting braces
40	Torx safety screw 6 × 30, A2 SS, torx	D	Fasten the wall slats to the supporting braces from outside the pool
372	Torx safety screw 6 × 20, A2 SS, torx	G	Fasten the coping modules to the coping brackets
90	Countersunk screw, 4x35 A4 SS, torx, threaded over 20 mm	H	Mount the Hung track under the coping
24	Domed head nail, 2.8 × 60, A2 SS	I	Fasten the finishing trim to the walls (3 nails per profile)
16	Countersunk screw 5 × 60 zinc plated torx threaded over 35 mm	K	Assembly of the wooden steps: fasten the 4 treads to the 2 rails

4	Countersunk screw 4 × 25 zinc plated torx	K	Mount the warning panel
34	Countersunk screw 5 × 100, A4 SS, torx, threaded over 60 mm	L	Mount the wooden coping brackets on the walls (2 × 17 consoles)
42	Countersunk screw 5 × 80, A4 SS, torx, threaded over 50 mm	L	Fasten the wooden supporting braces to the walls (× 18) Fasten the trim over the supporting braces (× 24)
68	Countersunk screw 5 × 40, A4 SS, torx, threaded over 25 mm	M	Fasten the metallic plates to the wooden coping brackets (4 × 17)
52	Countersunk screw 5 × 40, A4 SS, torx, threaded over 25 mm	Z	Assembly of the duckboarding (4 × 13 duckboarding)
4	Stud M10 × 130 A4		Fasten the pinch sockets to the slab

Pool structure metalwork

QTY	DESCRIPTION
1	Steel mounting elements kit:
	- Coping module fittings (× 10 right, × 10 left)
	- Corner coping module fittings (× 4)
	- Jacks for the supporting braces (× 4 back, × 4 front)
1	Metalwork kit:
	- Beam mounting unit counter plate(× 2)
	- Hand rail bracket (× 1 right, × 1 left)
	- Skimmer blocking bracket (× 1)
	- Pit wall bracket (× 2)
- Pit wall flange (× 2)	
17	Metallic plates to fasten the coping modules
2	SS pivot pin for the coping module hinge
4	Stainless steel supporting brace (inserted between the wooden elements pack and the automatic cover pack, screwed to the pallet)
2	SS pinch sockets to hold the wooden supporting braces

Integrated cartridge filtration system

QTY	DESCRIPTION
1	Pack: Filtration pump and unions
	- 90°elbow, Ø32, solvent, (× 2)
	- 3 part barrel union Ø32, solvent, (× 1)
	- Threaded nipples (× 3)
	- Simple reducing bush, Ø50 x 32 (× 2)
	- 1/4 turn valve Ø32, solvent (× 2)
	- Rigid PVC pipe, 30 cm, Ø32, to be cut and glued (× 3)
	- Pump, transformer
	- Filtration cartridge
- Pot of glue, Teflon tape	
1	Pool fittings pack
	- Skimmer (body, gasket, face plate, flange, screws, weir)
	- Return fitting (body, flange, eyeball, face plate, gaskets, screws)
	- SS ring and fabric sock for the pre-filter

Accessories

QTY	DESCRIPTION
1	Installation instructions
1	Warning panel to mount on the pool wall
1	Folder with safety documents
1	Bitumous strips to provide insulatation between the pool walls and the concrete slab
1	Roll of black plasticised PVC to protect the liner against screw heads
1	Underlay
1	Grey liner
13	1.18 m length of PVC liner locking track
2	SS hand rails
1	Static swim belt and SS bushing

2.5.2 Automatic cover pack

Mechanical assembly and automatic cover slat apron

QTY	DESCRIPTION
1	Anodised aluminium axle, Ø150, length 1790 mm, with two stands, a bearing and three supports to attach the slat apron
1	SS motor shaft, 309 mm, for the throughwall flange with plastic locking pin and screw
1	Throughwall flange (body, gaskets, flange and screws)
1	Bearing (body, gaskets, flange and screws)
1	Automatic cover apron (74 slats) fitted with three connection straps on the axle side and two safety fastening straps
2	Automatic cover safety fastener
1	Electrical panel with contol pad for the automatic cover, key switch, filtration timer and water slinger (o-ring) for the SS motor shaft,309 mm, inserted in the throughwall flange
1	Urban pool reduction geared motor with pins (pin for SS shaft and U shaped pin)
1	Lacquered aluminium beam 60 x 87 x 2988 mm with gaskets (4 wasjers and 4 plates) and 2 polyamide blocks
2	Pit wall module
1	LED underwater light
2	Black elastic strap to hold the automatic cover apron

Ladder rails

QTY	DESCRIPTION
2	Aluminium rails ,Ø40, and ball joints
3	ABS treads with aluminium screws
2	Support, shell and adhesive gaskets with SS screws
2	Bumpers to protect the liner

3. WOOD, A NATURAL MATERIAL

Being a natural material, wood will have some imperfections. These are normal and have no impact on the service life of the product.

A certain number are superficial and do not fall within the scope of the guarantees.

3.1 Colour variations

Colour variations are common to every species of wood. Treatment brings them out because the depth of penetration of the product depends on the wood density and grain. Weathering of wood outdoors will significantly attenuate these colour variations.



3.2 Resin beads

When resinous wood species are autoclaved, the alternating pressure and vacuum can cause sticky residue to rise to the surface. To remove it, scrape it carefully with an appropriate tool, being careful not to touch the wood. Turpentine spirits could also be effective, but could stain the wood if too much is applied.

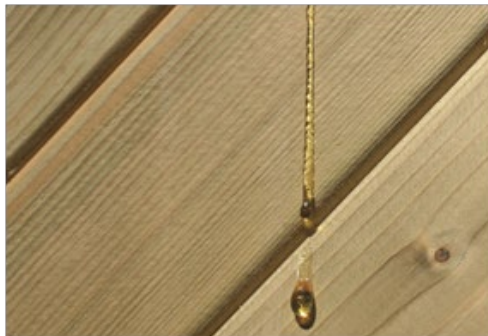

3.3 Salt stains

Small green stains are frequently found on the surface of autoclaved wood. These can be removed with light sanding. If left untreated, this colour will disappear over time.



3.4 Greying

Wood exposed to the sun and the moon is susceptible to greying. Some of the wood could already be greyed due to the storage conditions of the various elements of the structure. This is a natural phenomenon that has no impact on the structural integrity of the product. The colour of the whole structure will even out after a few months of exposure.



3.5 Splitting and cracking

Wood expands and contracts when exposed to variations in humidity and temperature. As it dries, wood contracts unevenly resulting in the appearance of cracks. While these can seem to be cause for concern, they have no impact on the mechanical properties of the product and therefore do not fall within the scope of the guarantee.



3.6 Knots

Knots mark the places where branches were attached. The quantity and size depends on the species of wood and the sorting process. For outdoor installations, small adherent knots are acceptable



3.7 Surface mould

Mould, caused by microscopic fungi, can grow on wood, particularly on resinous species, on which the growth can appear as “blueing”. It is a surface phenomenon, exacerbated by heat, humidity and inadequate aeration and is characterised by stains ranging from light to dark blue. They can be removed by wiping the surface.

Remember that class IV treated wood is protected against attack by fungi that could destroy the physical and mechanical properties of the wood.



3.8 Joined wood

To ensure the highest quality in the selection of our wood, it is sorted meticulously before planing. Sections that features defects on both sides are removed and the wood is then joined together (see image). This in no way penalises the mechanical properties of the wood.

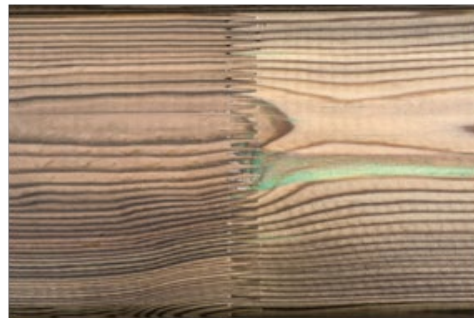

4. EARTHWORKS

4.1 Introduction

After determining the ideal position for your pool (preferably, orient the pool so that skimmers face into dominant winds), start with the excavation required to accommodate the concrete slab that will seal in the support braces and form the base of your pool. Seek the assistance of a professional if required.

Never backfill under the pool to achieve a level surface, the layer of stone bedding and the slab must be seated on stable ground.

In this section on earthworks, information provided takes into account the plant housing and the drainage system required for an in-ground or partially in-ground installation. For an above-ground installation, the plant housing and drainage system are not required. The excavation and the slab will be rectangles, 6600 mm long and 3100 mm wide.

4.2 Creating the excavation

4.2.1 Material quantities

The quantities of materials required are shown in the table below:

Estimated volume of stone bedding	2.5 m ³	20/40 gravel
Geotextile surface area (pool floor)	21.5 m ²	nonwoven felt
Polyethylene film surface area	21.5 m ²	polyethylene sheet
Theoretical length of the Ø80 mm drain	21.5 m	PVC
Rebar	23 m	ST25C rebar
Slab, 15 cm thick	3.5 m ³	C25/30 concrete
Protective membrane for in-ground walls (rolls 1.5 m high)	21 ml	polyethylene
Backfill	13.5 m ³	10/20 rolled gravel

4.2.2 Excavation

Dig out an area, the length and the width of which should correspond to the length and width of the inner walls of the pool increased by 0.55 m around the entire periphery of the pool. In the event that the pool is to be installed entirely in-ground (bottom of the coping flush with the ground), the hole should be 1.56 m deep. For an above-ground installation, so that the slab is flush with the ground, excavate to a depth of 0.26 m. For partially in-ground installations, the depth of the hole is determined by the installer.

For example, to sink the pool 1 m into the ground (leaving 33 cm above ground), the hole should be 1.26 m deep.

4.2.3 Drainage

In the case of an in-ground installation, create a drain around the entire outer periphery of the pool. The drain, which should have a diameter of 80 cm, should be connected to a relief well located in one of the corners on the outside edge of the excavation. The relief well should be 0.5 m deeper than the floor of the excavation and should have a diameter of at least 0.3 m to accommodate a lift pump.

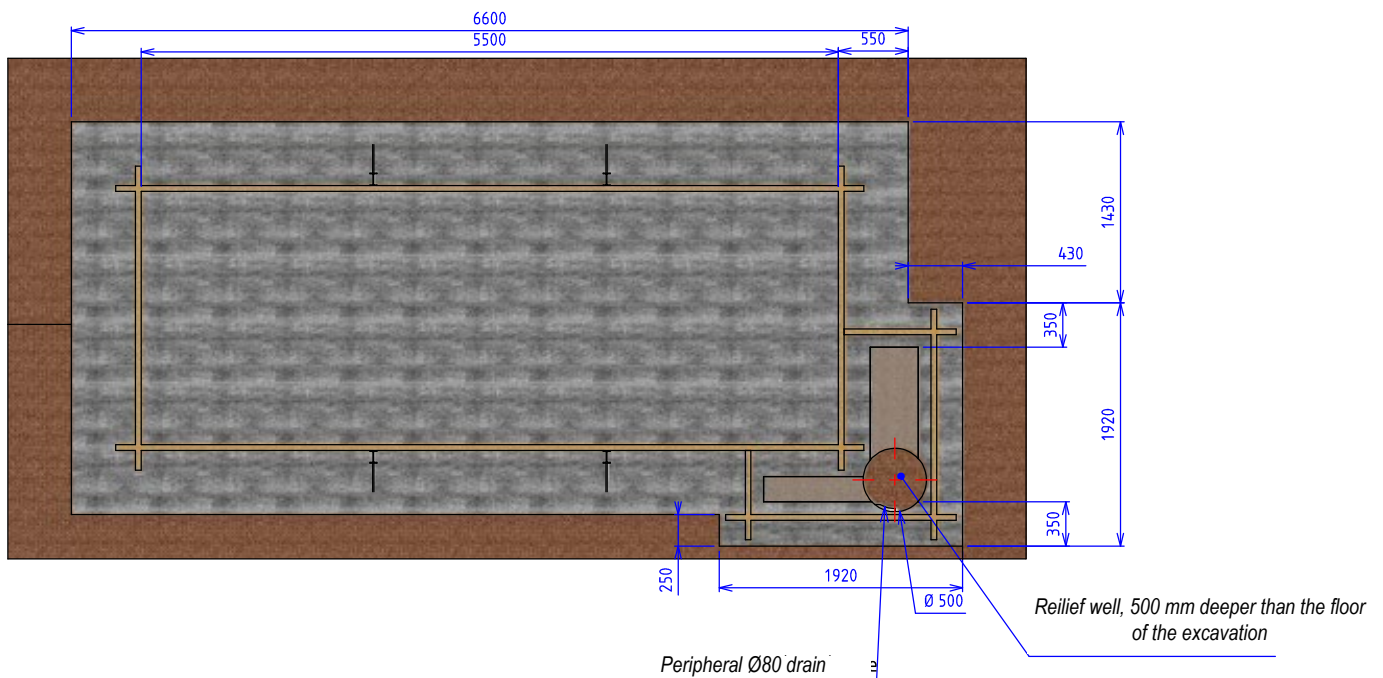
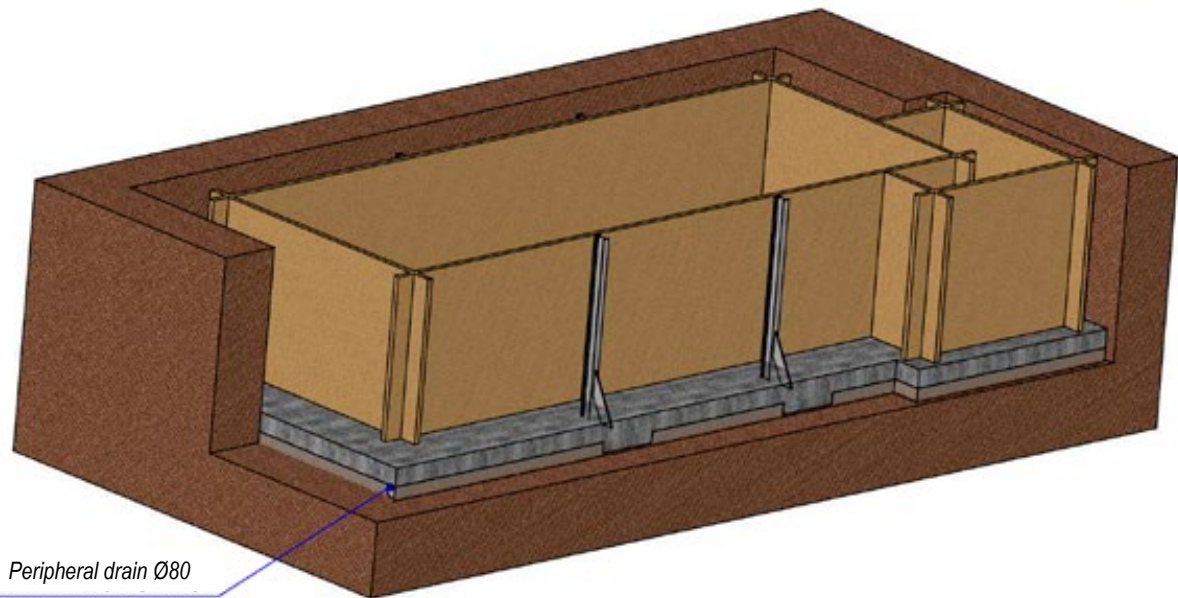

Figure 1 – Creating a drainage system

4.2.4 Stone bedding

Level the floor of the excavation as much as possible, and then roll out the geotextile to cover the entire floor. Using 20/40 mm gravel lay hardcore to a depth of 110 mm around the entire periphery of the excavation. Correct tamping of the gravel will ensure a neat finish of the excavation floor, and facilitate installation of the supporting braces.

Remove the gravel at the positions shown in [Figure 2](#) in order to create four 500 × 650 mm recess 90 mm deep (as measured from the surface of the stone bedding). The recesses will accommodate the steel braces, once imprisoned in the concrete, these braces will support the pool structure.

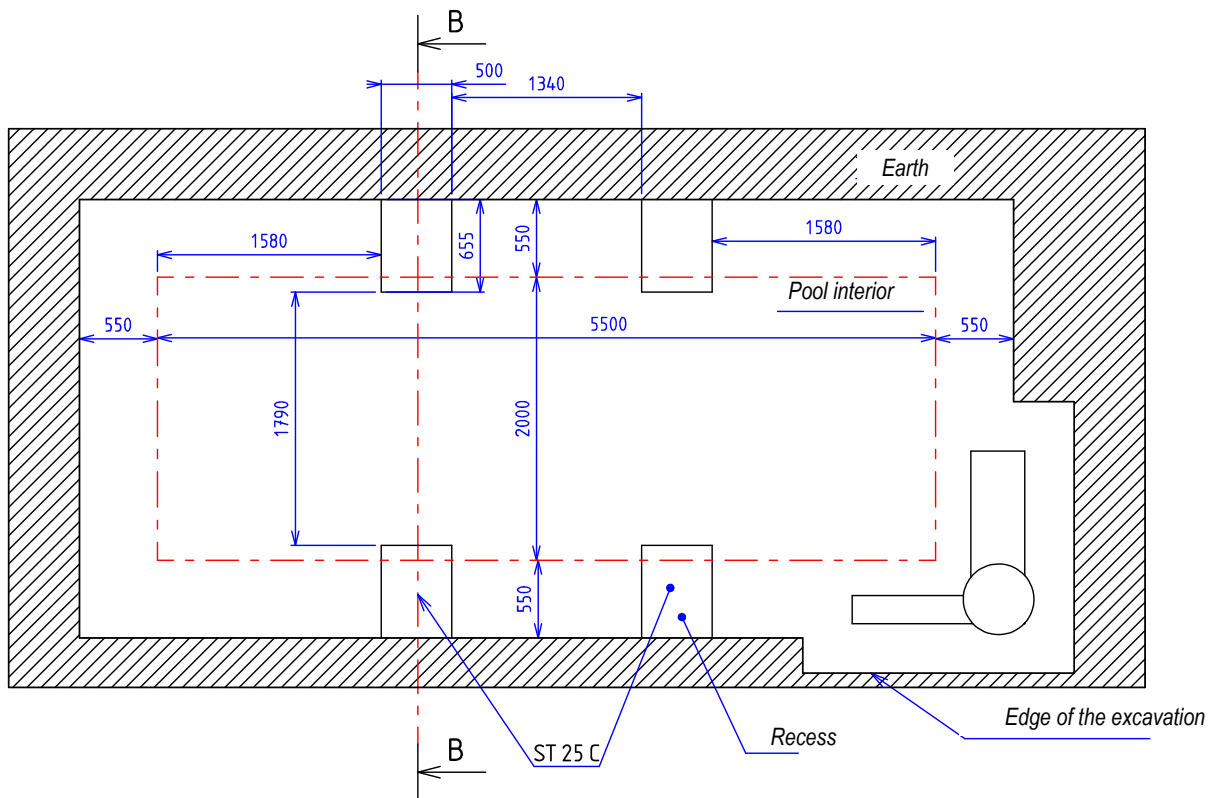

Figure 2 – Locations of the recesses intended to accommodate the support braces.

4.3 Installing the supporting braces

Lay rebar (type ST25C) at the bottom of the recesses that will accept the support braces. This will hold the concrete blocks that will imprison the supporting braces.

Install the supporting braces in each of the four locations, having first fitted the recesses with jacks (*Figure 3* and *Figure 4*). Use 4 double acting jacks, 4 single acting jacks and 24 screws with a diameter of 10 mm (bag A). The top screws should be inserted after the height of the bottom screws has been adjusted.

! The supporting braces must under no circumstances extend above the top of the pool wall (just beneath the coping) after adjustment of the supporting brace jacks. On the contrary, it is not problematic if the top of the supporting braces are 1 or 2 cm below the top of the pool wall.

After assembly, adjust the supporting braces and check carefully that they are correctly positioned: plumb, level, correct alignment of the supporting braces. To ensure that the supporting braces stay in place after adjustment, you can pre-seal them with a small amount of concrete.

TIP: You can use the supporting braces to visualise how high the concrete slab should be once it has been poured. To do this, taking the top of the pool wall, below the coping, as level 0 (see *Figure 5*), measure 1.303 m and mark this distance on the front of the supporting brace. This mark will correspond to the height of the finished concrete slab.

! Take particular care while carrying out these assembly steps, they will determine the quality of the pool finish. Incorrect positioning of the supporting braces may render assembly of the pool walls impossible.

! Check that all the dimensions quoted in figure 4 are correct before proceeding with the next step.

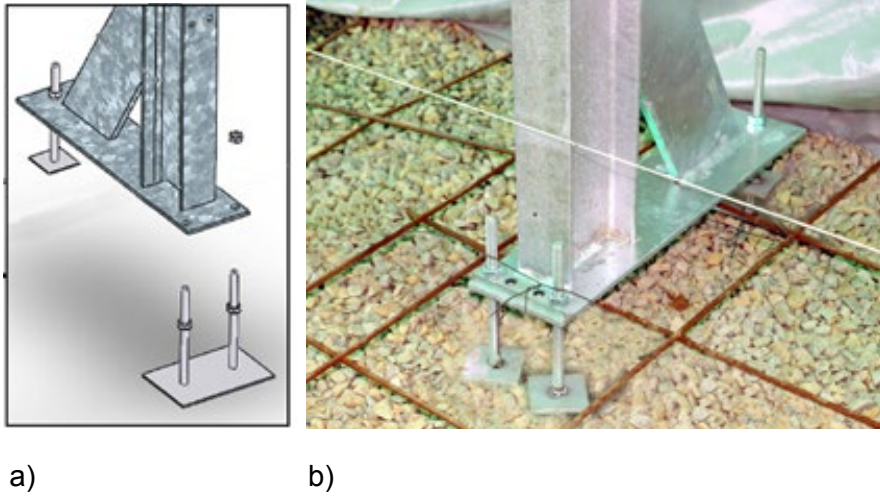
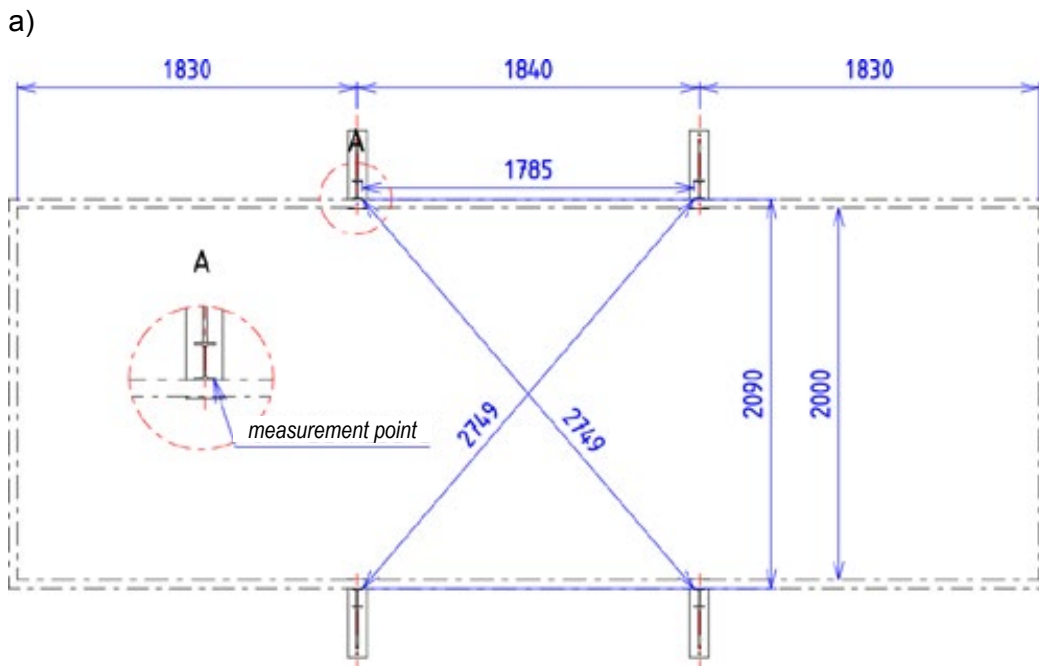
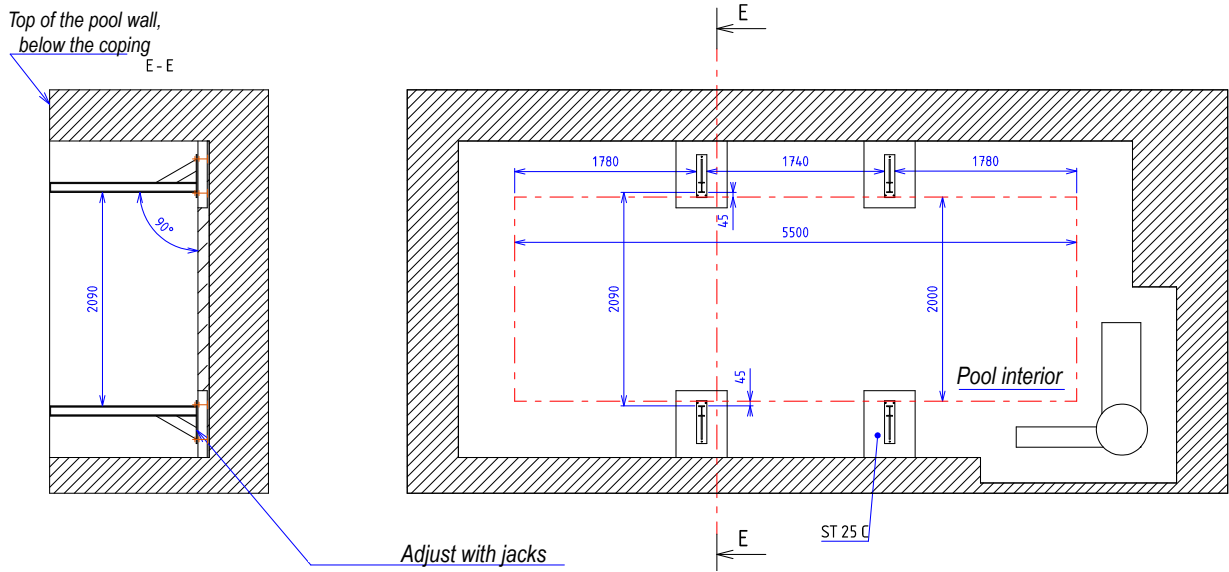

Figure 3 – a and b - Positioning the jacks under the supporting braces



b) Figure 4 – a and b - Positioning the supporting braces

4.4 Pouring the concrete slab

4.4.1 Rebar

Before pouring the concrete, lay the top layer of welded rebar mesh (type ST25C) over the floor of the excavation (the mesh should be set back 3 to 5 cm from the edge around the entire periphery). Some cutting around the supporting braces will be necessary. The mesh should overlap by one and a half squares and should be connected together using metal ties. The mesh should be raised using spacers to ensure that will sit in the centre of the slab. If you are using self-levelling concrete, you should place a layer of polyethylene sheeting under the rebar mesh because the concrete is very liquid and could flow into the spaces between the gravel. Use C25/30 grade concrete as a minimum.

4.4.2 Slab dimensions

The characteristics of the concrete slab are provided in *Figure 5*. The dimensions of the slab are such the feet of the wooden pool access ladder will not rest on the slab. However, we recommend that the feet of the ladder rest on a solid surface (cement blocks or slab for example).

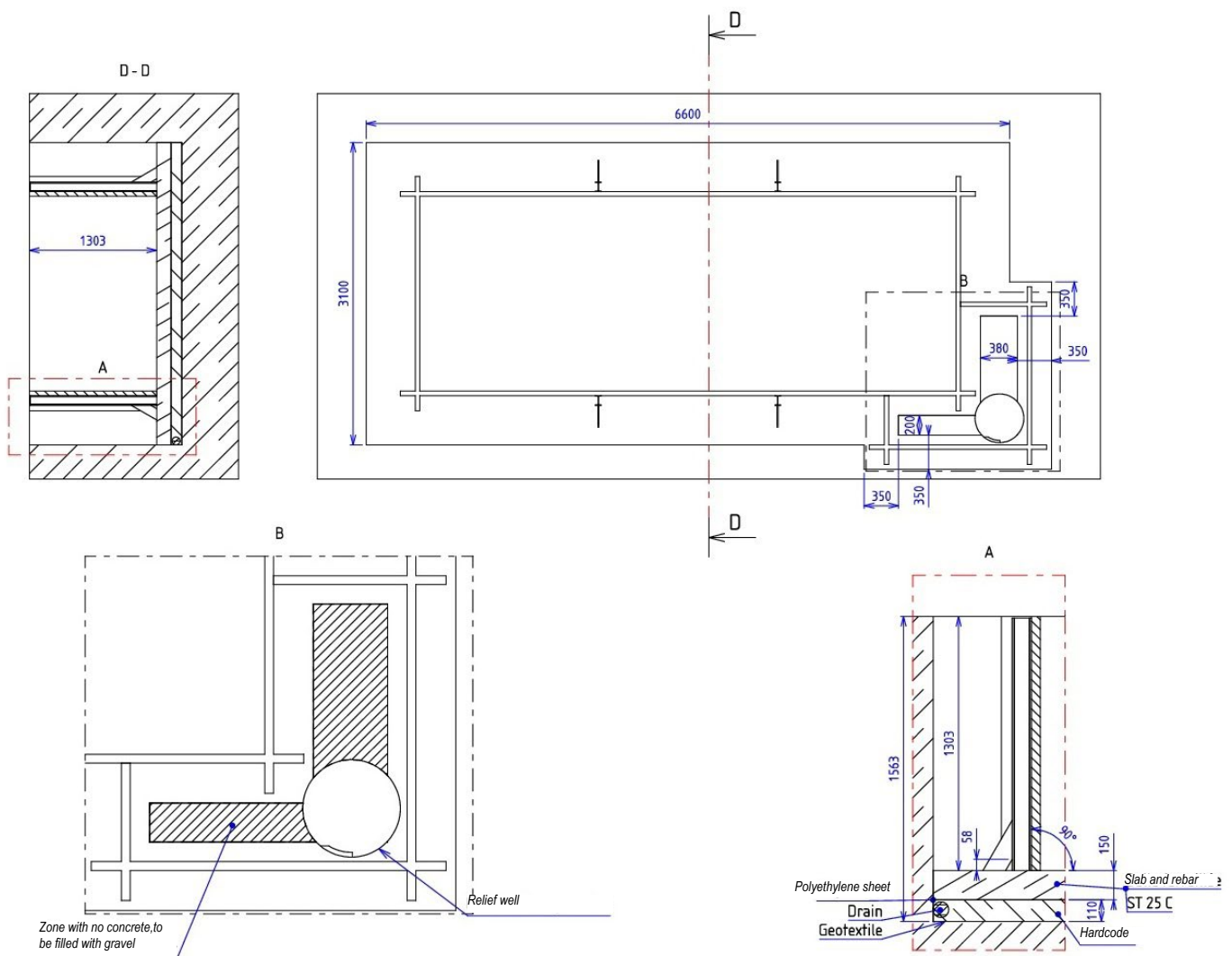

Figure 5 – Characteristics of the concrete slab

While pouring the slab over the floor of the excavation, make sure that the upper rebar mesh is properly encased in the concrete: the layer of concrete above the mesh must be at least 3 cm thick. Refer to [Figure 5](#) to determine the depth of the slab to be poured: it should be 150 mm thick, and of a height to ensure that the distance between the surface of the slab and the top of the excavation is 1303 mm if the pool is to be installed in-ground.

Level and smooth the slab carefully to void surface defects that will have to be corrected later.



The slab provides seating for the wooden structure. Any levelling defects will become apparent when the pool is filled with water. Similarly, significant surface defects will detract from the quality of the finish of the pool floor.

5. ASSEMBLING THE WOODEN STRUCTURE

5.1 Introduction

You may begin assembly of the pool walls 2 to 3 days after the slab is poured without waiting for the concrete to cure completely. However, you must wait at least 3 weeks for the concrete to cure before filling the pool with water.

Before starting to assemble the wooden walls, make sure that the slab is free from any defects and that it is perfectly level. The finish of the concrete slab will determine the correct seating of the walls, the quality of the pool floor and the finish of the pool. A level defect will be accentuated and visible when the pool is filled with water. It could also make it impossible to assemble the pool walls. If necessary, correct defects by sanding or resurfacing the slab.

Your pool is comprised of several slat references, the positions of the slats are illustrated on various diagrams ([Figure 6](#) and [Figure 7](#)). There are specific slats to house the pool fittings (skimmer, return fitting, beam mounting unit and throughwall flange required to mount the automatic cover axle). Assembly of this structure is described step by step in this section.

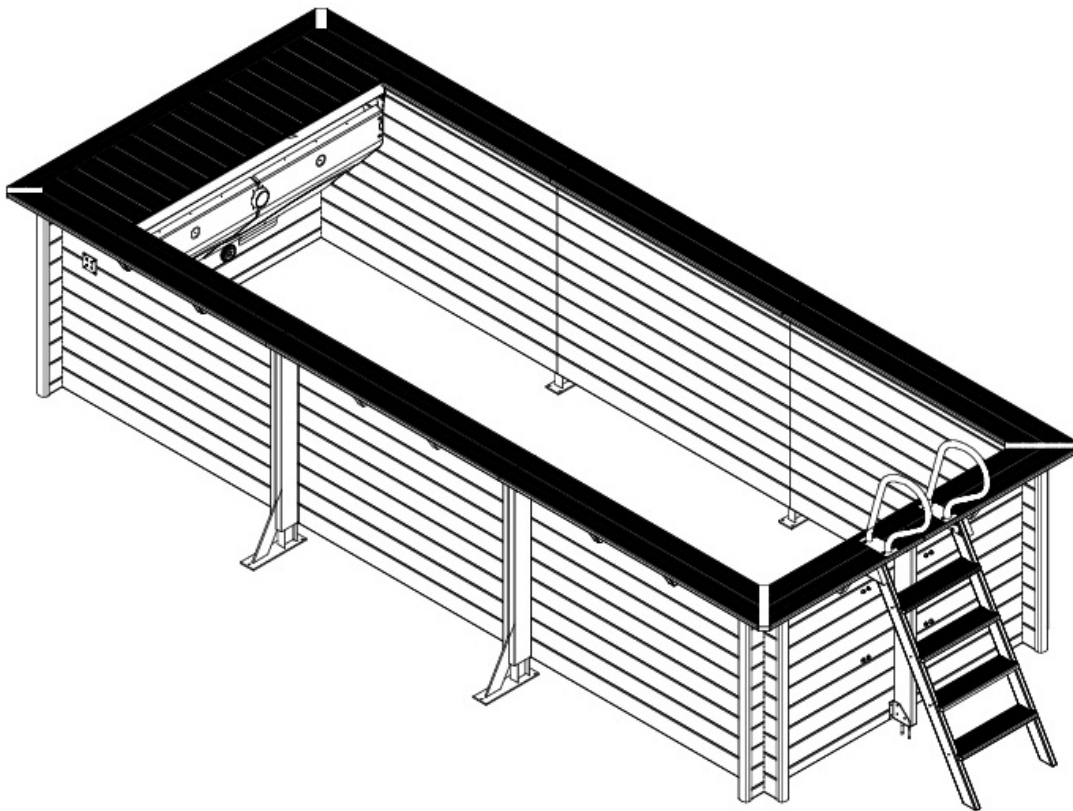
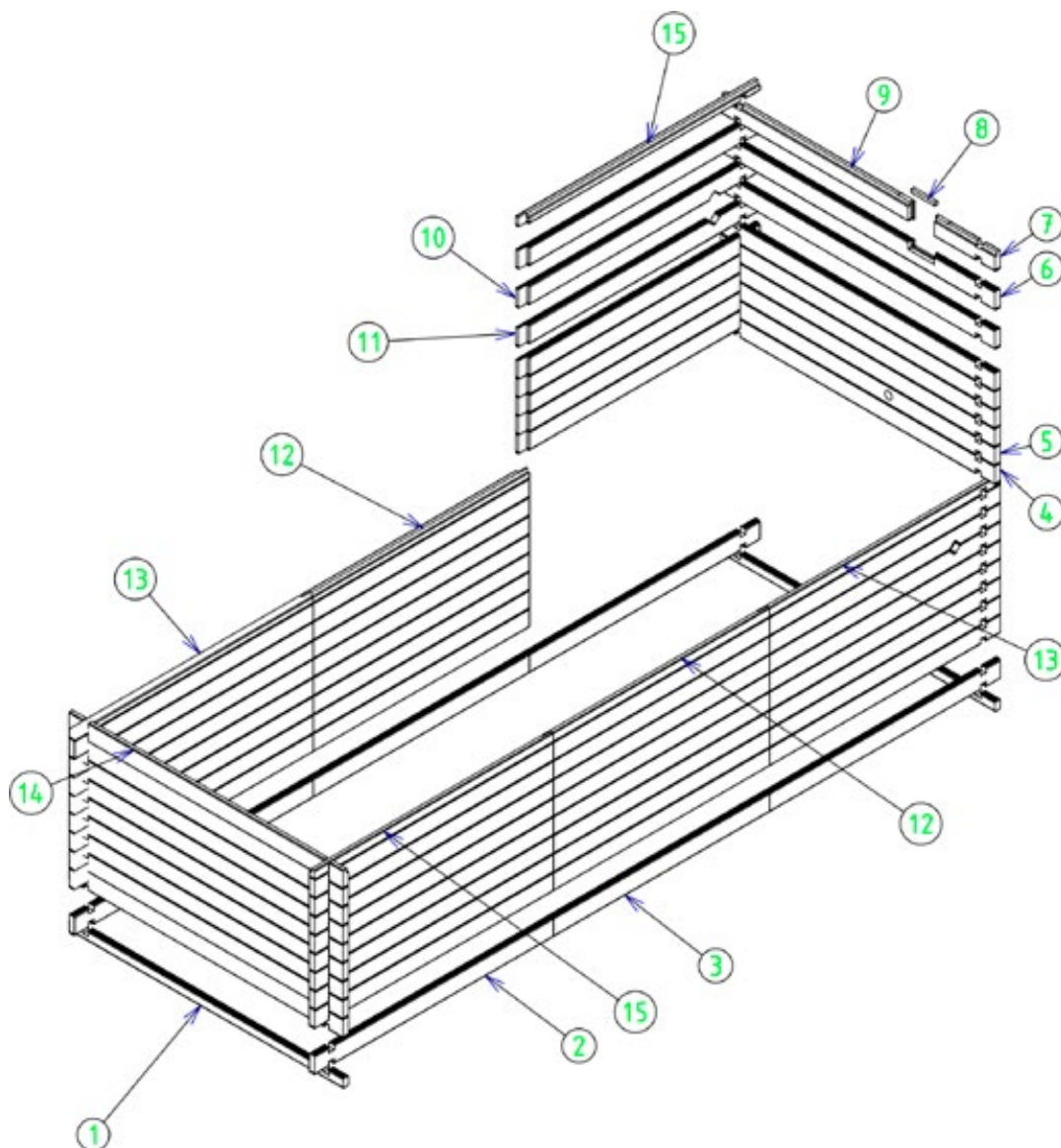

Figure 6 – General diagram of an Urban pool



NUMBER	QUANTITY	DIMENSIONS (MM)	TYPE	SPECIFIC
1	2	2332 x 78 x 45	male slat	
2	32	2031 x 145 x 45	male/ female slat	
3	18	1908 x 145 x 45	male/ female slat	
4	14	2332 x 145 x 45	male/ female slat	
5	1	2332 x 145 x 45	male/ female slat	return fitting
6	1	2332 x 145 x 45	male/ female slat	skimmer
7	1	528 x 137 x 45	female slat	skimmer
8	1	200 x 25 x 25	cleat	skimmer
9	1	1604 x 137 x 45	female slat	skimmer
10	2	2031 x 145 x 45	male/ female slat	throughwall flange
11	2	2031 x 145 x 45	male/ female slat	throughwall flange
12	2	1908 x 70 x 45	female slat	
13	2	2031 x 70 x 45	female slat	
14	1	2332 x 137 x 45	female slat	
15	2	2031 x 70 x 45	female slat	

Figure 7 – Exploded view of the wooden structure

5.2 Application of the bituminous strips

Start by unrolling the bituminous strip that will insulate the wooden structure from the concrete slab (*Figure 8*).



Figure 8 – Laying the bituminous strips

5.3 Assembling the slats

Lay out the $\frac{1}{2}$ slats that constitute the pool widths, then, in the corners, slot in the slats that constitute the pool lengths. After laying out the first row of slats, make sure that the diagonals are equal.

Fit the slats together, according to the assembly diagram shown in *Figure 9* and taking care to position the machined slats correctly (see *Figure 7*). The tongues should always be oriented upwards, and the grooves downwards.

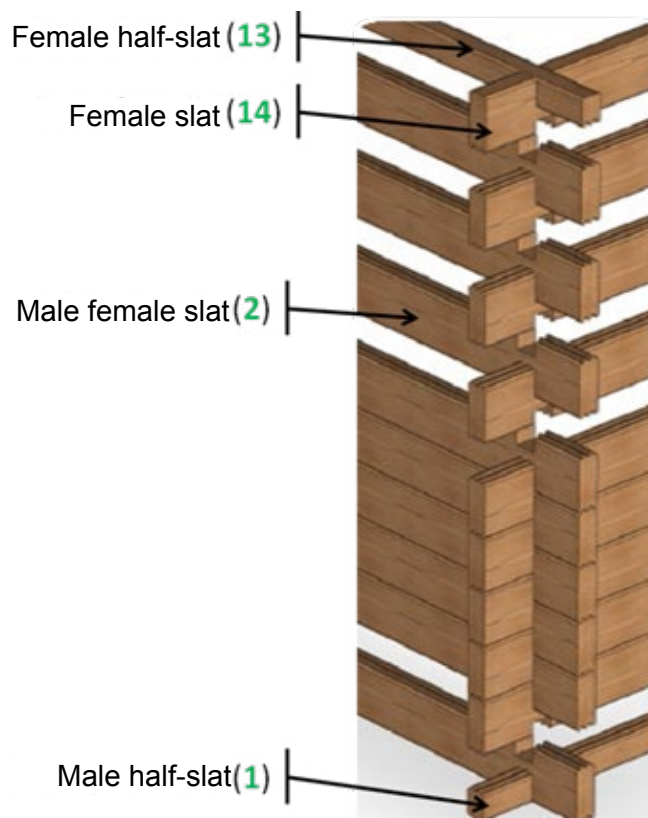

Figure 9 – Slotting together the wooden slats



While assembling the pool walls, make sure as of the first rows that the slats are fully engaged in the grooves. After assembling the first row, check that the slats are perfectly level, screw together the slats constituting the pool lengths:

- referring to *Figure 10*, screw the slats together using 2 screws per pair of slats in each of the 10 rows, that is, 80 countersunk screws 5 × 40 A4 SS torx threaded over 25 mm (bag C) ;
- fix them to the 4 supporting braces (these are pre-drilled as shown in Figure 11) using 36 torx safety screws 6 × 30 A2 SS (bag D).

For correct assembly, it may be necessary to use a mallet and clamp to remedy light slat deformations caused by storage. Do not strike the wooden slats directly, use the protective martyr blocks.

! The heads of screws inserted from the inside of the pool should be flush with the pool wall to avoid damaging the liner.

Remove any splinters raised by the screws as you go.

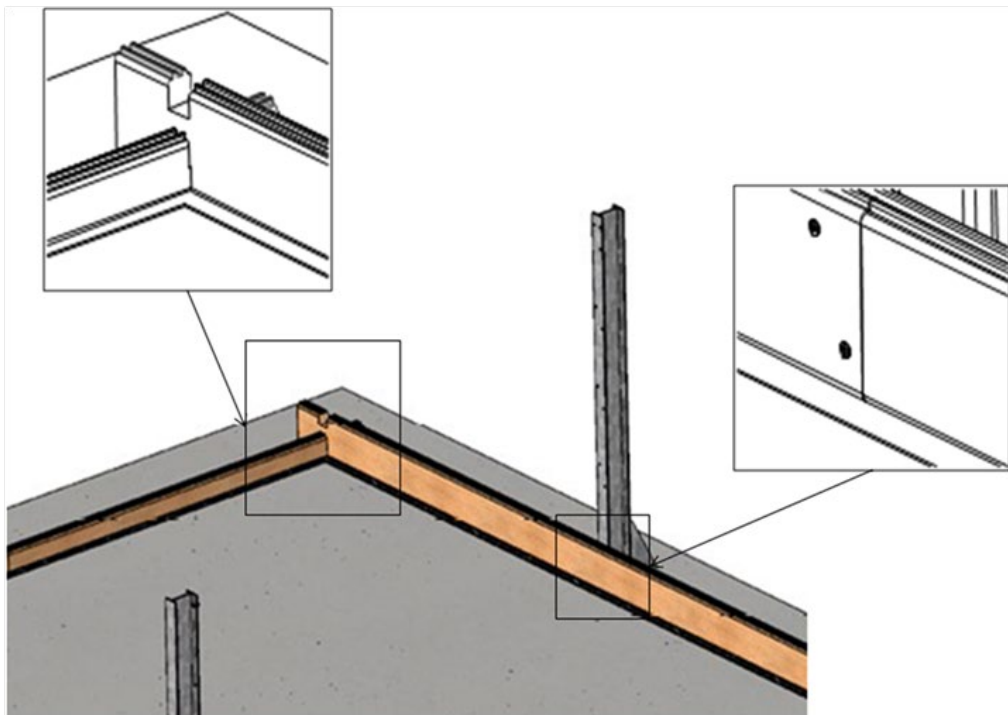

Figure 10 – Screwing the slats together

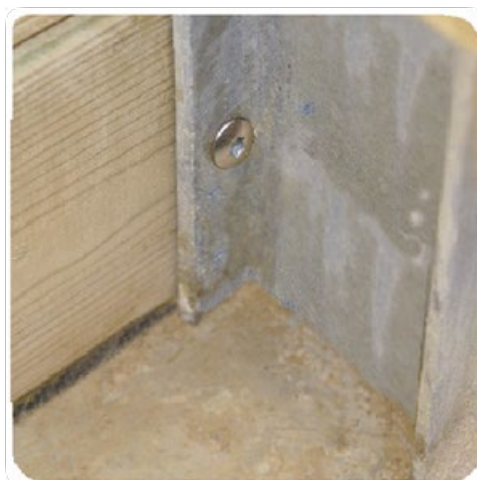

Figure 11 – Fastening the slats to the supporting braces

5.4 Mounting the finishing trim on the supporting braces

Put the supporting brace finishing trims in position. They should be flush with the top of the pool wall. Working from the inside of the pool, insert screws as shown in *Figure 12* using 3 countersunk screws 5 × 80 A4 SS torx, threaded over 50mm (bag L) per half trim, that is a total of 24 screws. The 2 half trims do not meet, the metallic brace will remain visible.

Should it be necessary to resize the trims (for example, if the pool is installed partially in-ground) orient the cut surface upwards so that the cut side is not in contact with the ground.

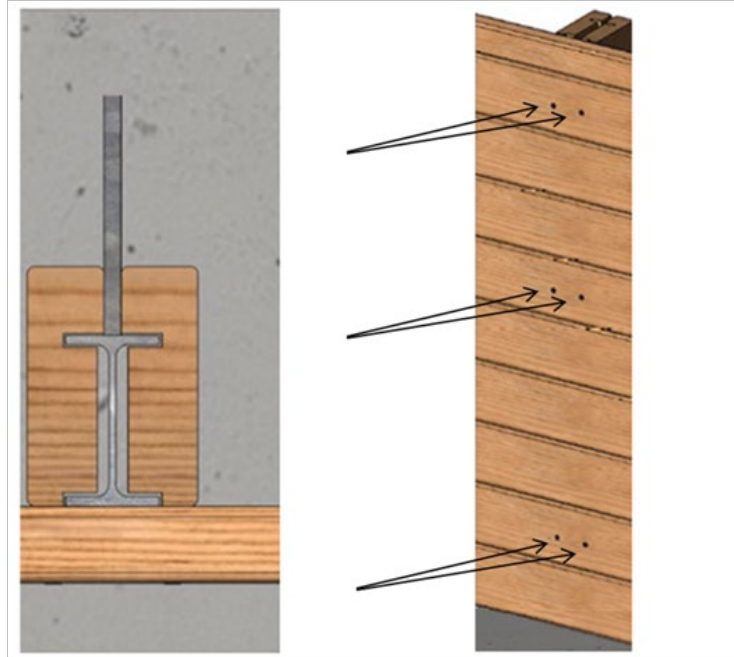

Figure 12 – Mounting the supporting brace finishing trime

5.5 Fitting the supporting brace pinch sockets

Fasten the two pinch sockets to the middle of the pool widths (1000 mm from the edge of pool walls as shown in *Figure 13*) using four studs M10 x 130 in A4 SS. To do this drill two holes with a diameter of 10mm, using a concrete drill bit and a drill, or a percussion drill.

Fasten each pinch socket to the walls using an additional four torx safety screws 6 x 20 in A2 SS (bag G) per socket, that is an additional 8 screws in total.

Insert the two wooden supporting braces 1285 x 145 x 45 into the shoes and fasten them to the shoes using 12 security screws 6 x 20 in A2 SS (bag G). Working from inside the pool, fasten the wooden supporting braces to the pool wall. Screw each of the 9 full slats constituting the pool wall to the wooden supporting brace using 9 countersunk screws 5 x 80, threaded over 50 mm, that is a total of 18 screws.

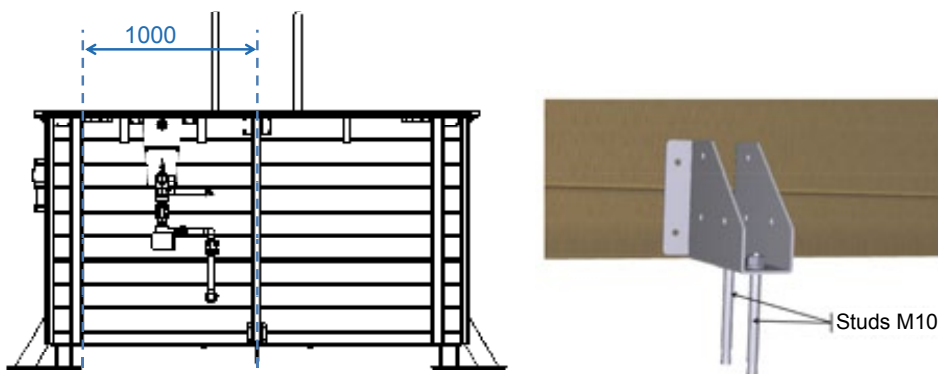

Figure 13 – a et b - Fitting the supporting brace shoes

5.6 Mounting the coping brackets

Fasten a metallic mounting plate to each of the 17 wooden brackets using 4 countersunk zinc plated screws 5 x 40, torx, threaded over 25 mm (bag M), that is a total of 64 screws, as shown in *Figure 14*:

- 15 standard brackets: the edge of the width of the metal plate that does not have rounded corners should be aligned with the vertical surface of the bracket that is in contact with the pool wall,
- 2 special (offset) brackets: the edge of the width of the metal plate that does not have rounded corners should be set back 5 mm from the vertical surface of the bracket that is in contact with the pool wall.

Referring to the diagram provided in *Figure 15* fasten the wooden brackets, furnished with metallic mounting plates, to the pool wall using two screws per bracket, that is a total of 34 countersunk screws, 5 x100 A2 SS, torx, threaded over 60 mm (bag L). The metallic mounting plates should be facing upwards.

The two special brackets should be positioned at the locations circled in red on the diagram in *Figure 15* (along the lengths, on the skimmer and automatic cover axle side).

In any case, the metallic mounting plates should be flush with the top of the pool wall. Check that the plates are level to allow subsequent mounting of the coping.

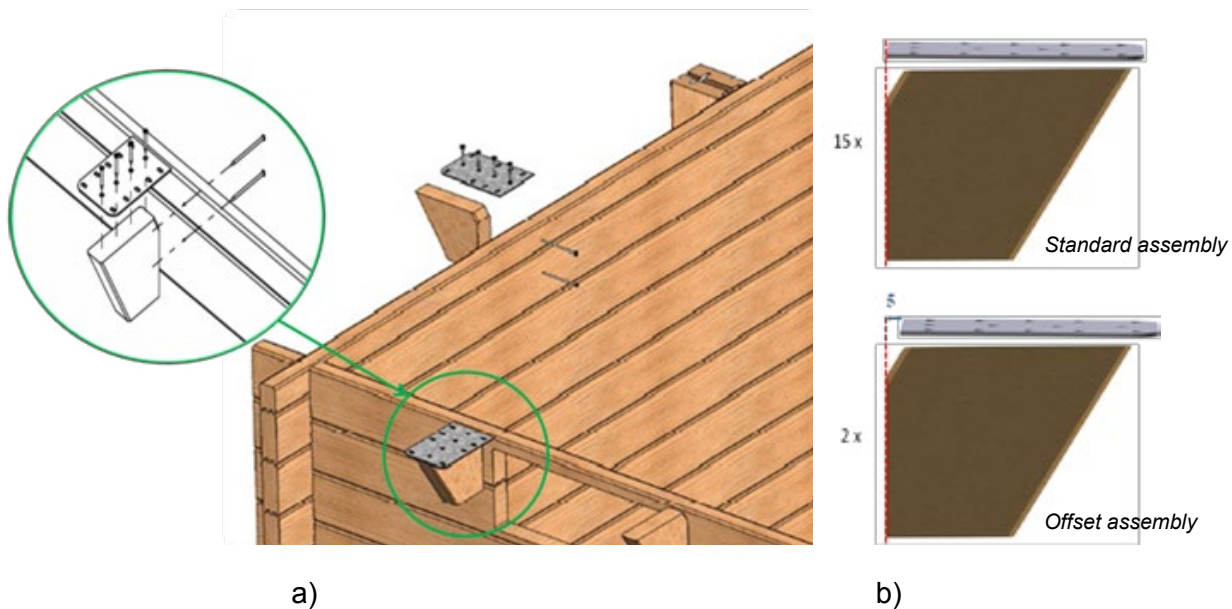

Figure 14 – a and b - Fastening metallic plates to the wooden brackets

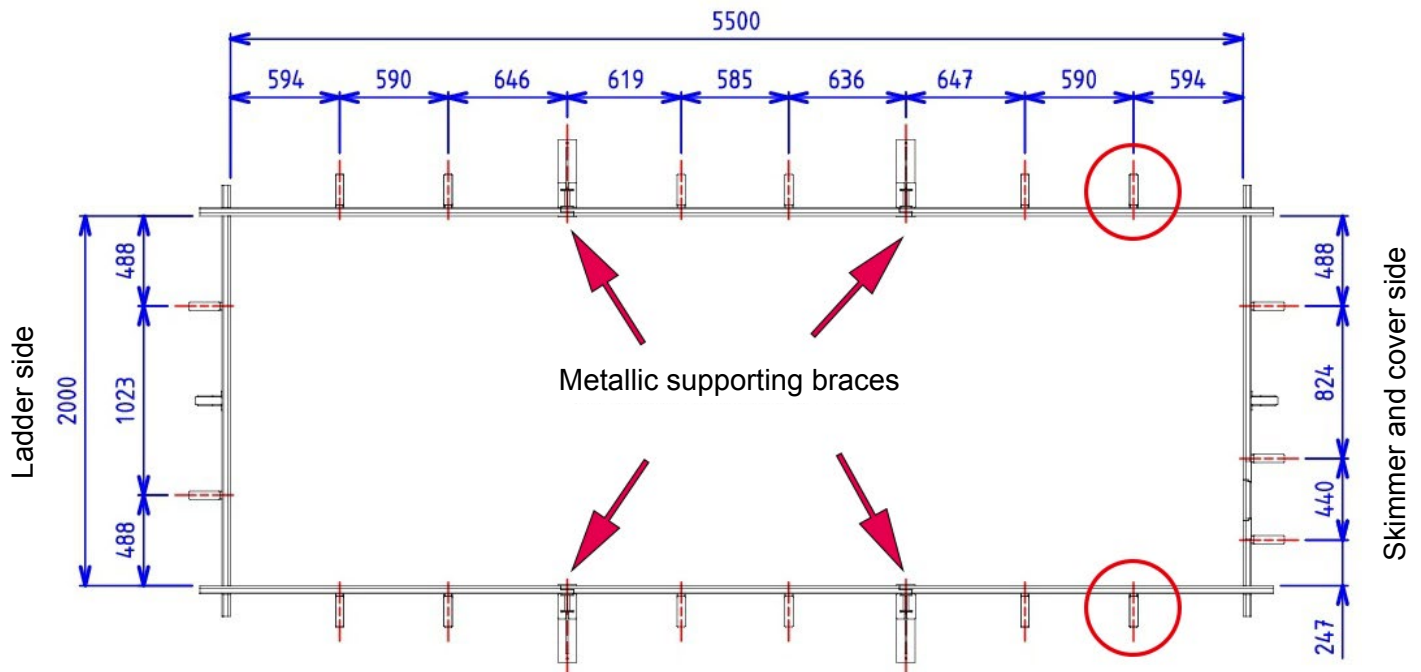

Figure 15 – Coping mounting bracket positions

5.7 Assembling the wooden access ladder

Assemble the ladder according to [Figure 16](#) using 16 zinc plated countersunk screws 5 × 60, torx, threaded over 35 mm (bag K), and fasten the handrail brackets to the right and left hand side of the ladder using 8 zinc plated countersunk screws, 4 × 25, torx (bag K).

Next, with 8 hinge screws 6 × 20, A2 SS (bag G), use the left- and right-hand handrail brackets to fasten the ladder to the pool wall as shown in [Figure 17](#).

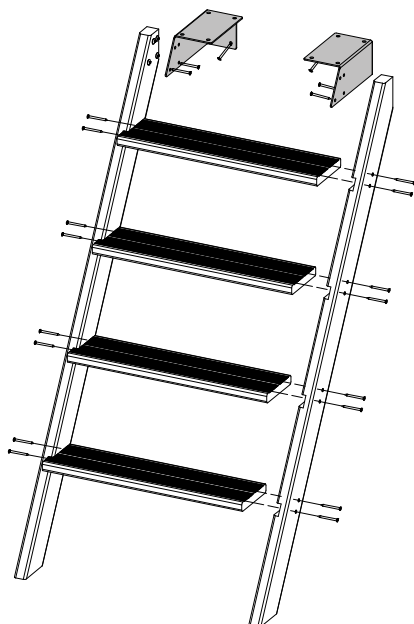

Figure 16 – Assembling the wooden access ladder



Figure 17 – Fastening the access ladder to the pool wall

For your own comfort, we recommend that you mount the ladder on the wall opposite the skimmer. In any case, do not locate the ladder within the third of the pool that contains the automatic cover axle.

The ladder must be located at least 30 cm from the corners of pool. Remember that wooden access ladder and in-pool ladder should face each other.

5.8 Mounting the metal fittings

The metal fittings are intended to support the coping and allow them to be fixed in position. Make sure that they are correctly positioned. They should be flush with the top of the pool wall and aligned with each other and the coping bracket plates.

- On top of each of the 4 metallic supporting braces and the two wooden supporting braces, place a 'right-hand' fitting and a 'left-hand' fitting from the 'Fastening elements' kit as shown in [Figure 18](#). Use 6 hinge screws 6 × 20 in A2 SS (bag G) per fitting, that is a total of 72 screws.
- In each of the corners, mount a right-hand fitting, a left-hand and a corner fitting as shown in [Figure 19](#). Use 4 hinge screws 6 × 20, A2 SS (bag G) per corner fitting 6 hinge screws 6 × 20 in A2 SS (bag G) per left- and right-hand fitting, that is a total of 64 screws.

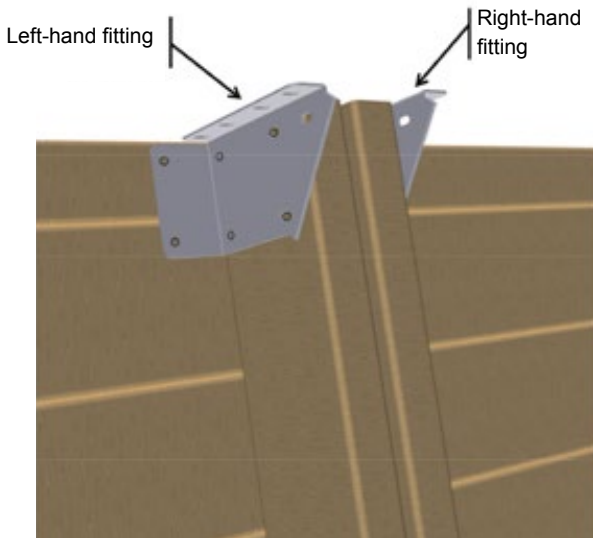

Figure 18 – Mounting the fittings on top of the supporting brace

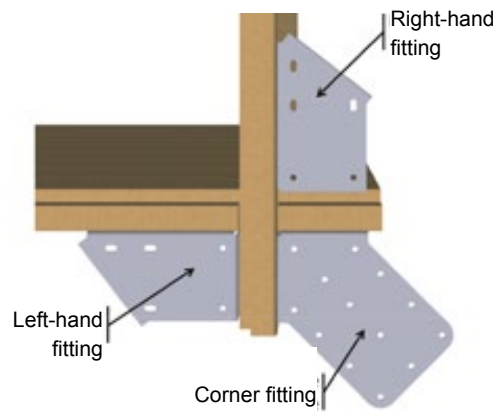

Figure 19 – Mounting the fitting in the corners

5.9 Finishing trim

Use 3 convex head nails, 2.8 x 60 A2 SS (bag I) to fasten the wooden finishing trim to the edge of each wall. The nails should be evenly spaced and the finishing trim should be pre-drilled using a drill bit with a diameter of 4mm. ([Figure 20](#)).



Figure 20 – Wooden trim

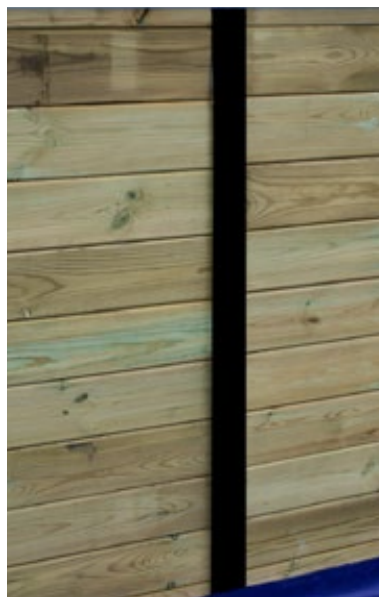

Figure 21 – Protective adhesive strip

Apply an adhesive strip (roll provided) to the vertical joints on the inner walls of the pool taking care to ensure that the screw heads are covered ([Figure 21](#)). This will protect the liner from the screw heads that could damage it.

6. INSTALLATION OF THE FILTRATION SYSTEM

6.1 ABS fittings

When mounting the ABS fittings, do not over-tighten, this could fracture the parts.

6.1.1 Skimmer

Mount the grey tube, external diameter 60 mm, length 34 mm, on the skimmer body at the location circled in red in *Figure 22*. Push it in fully, but do not use glue. This tube will wedge the skimmer, holding it in its vertical position against the wooden wall.

Next, slide the skimmer into the purpose made cut-out in the top slat. The front part of the skimmer should be flush with the inner pool wall.

Place the wooden cleat (in red in *Figure 23*, and the metal bracket over the skimmer as shown in *Figure 23*, to block the skimmer in position. Fasten the bracket and the cleat to the wall using:

- 6 countersunk screws 5.5 × 25 A4 SS (bag of screws enclosed with the skimmer) for vertically oriented screws, inserted from above,
- 4 hinge screws 6 × 20 A2 SS torx (bag G), for horizontally oriented screws.

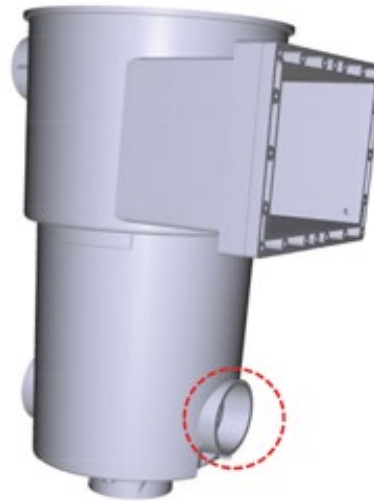

Figure 22 – Mounting the wedge on the skimmer

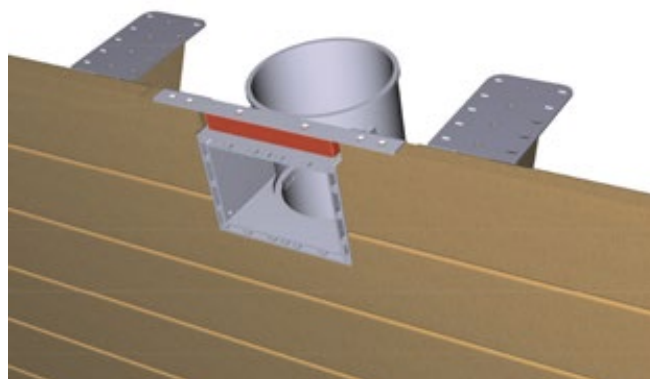

Figure 23 – Mounting the skimmer bracket

Glue the skimmer gasket to the front face, making sure that the holes in the skimmer and the gasket are correctly aligned. The liner must be installed within the following 48 hours. (Paragraph 9.5). If this is not possible, defer mounting the gasket until you are just about to fit the waterproofing membrane. The rest of the part (gasket and flange) will be added after the liner has been fitted to ensure that the skimmer is leaktight.

6.1.2 Return fitting body

Working from inside the pool, push the return fitting body into the opening in the machined slot (*Figure 24*). Fasten it to the wall using 4 countersunk pozidrive wood screws, A4 SS (bag of screws enclosed with the return fitting).

Apply the self-adhesive gasket to the through wall flange. As in the case of the skimmer, the liner must now be fitted within the next 48 hours (Step 0). If this is not possible, delay application of the gasket until just before the waterproofing membrane is fitted.



Figure 24 – Mounting the return fitting body and gasket

The rest of the part (gasket and flange) will be added after the liner is fitted to ensure leaktightness at the return fitting.

6.2 PVC pipework for filtration

Carry out a trial assembly of the pipework, as shown in *Figure 25*. The dimensions shown in this figure correspond to cuts that you will need to make in the 90 cm long 32 mm diameter PVC tube provided. Make sure that there is no stress loading on the PVC unions, because, over time, stress loading could damage the various parts and cause leaks. Use Teflon tape to ensure that the seal on the threaded unions is leaktight. The tape should be rolled flat over the threading. Looking at the threading from the front, wrap the tape 5 times clockwise around the threading. Rub the tape to work into the grooves of the threading.

Next, deburr the cut surfaces of the pipes and glue them. For glueing, you will need PVC stripper, a pot of glue for rigid PVC (provided), and medium grain sand paper.

! Do not forget to thread the locking nuts onto the pipes before glueing (two locking nutss per valve, one locking nut at the barrel union).

Rub the male and female surfaces of the parts to be glued with sand paper and then wipe them with stripper using a clean dry cloth. Apply a generous layer of glue over the entire male and female zones to be glued, then slot one into the other without twisting. Wipe off excess glue using a clean cloth. Allow 8 hours for the glue to cure before allowing water into the pipes.

! After glueing, the parts may be handled but should not be twisted or turned.

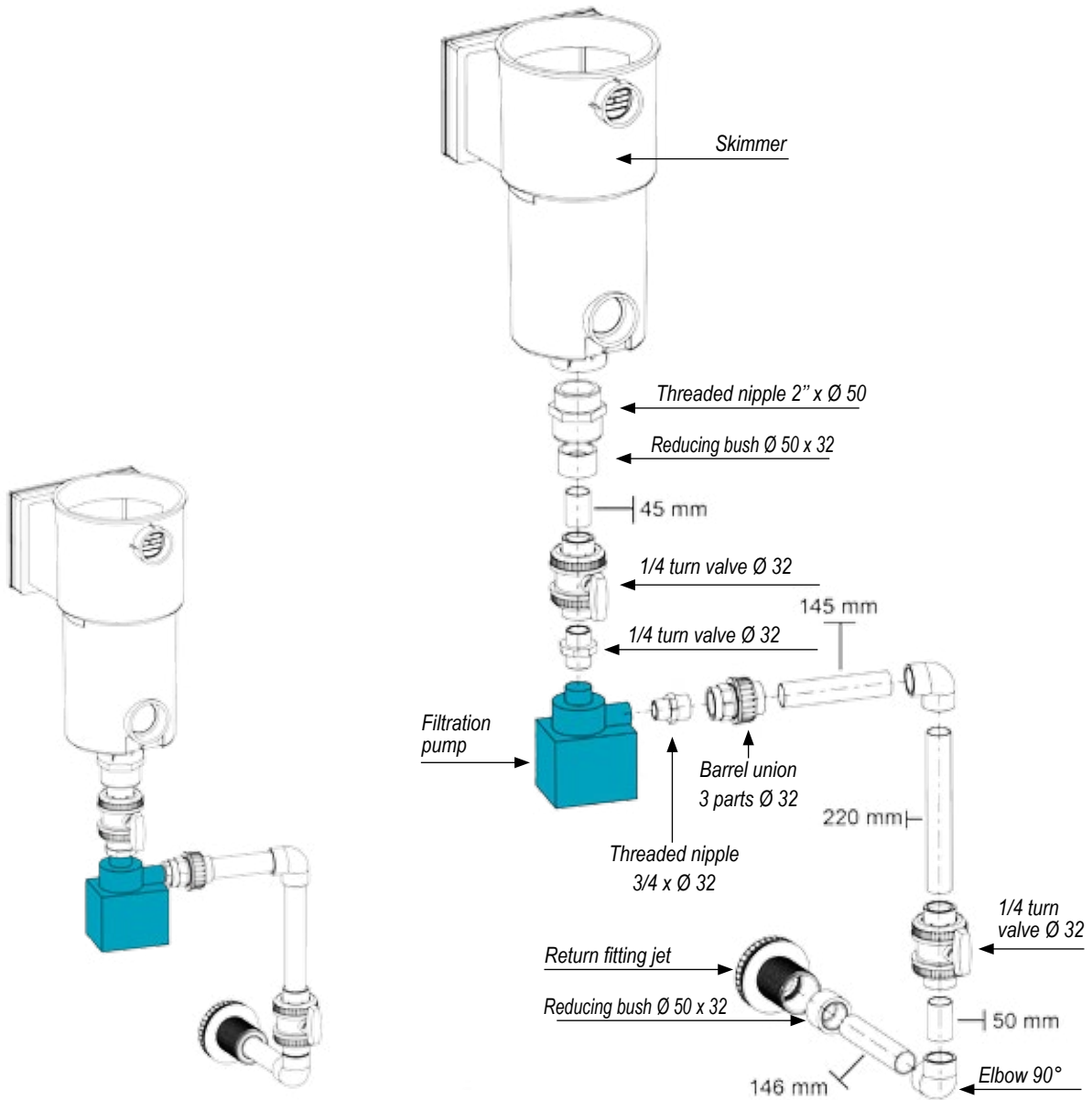

a)

b)

Figure 25 – a and b Filtration pipework

7. PARTS FOR THE AUTOMATIC COVER

7.1 Throughwall flange

The throughwall flange holds the axle in the pool wall and allows transmission of rotation between the motor and the automatic cover axle.

It should be mounted on the same side as the skimmer, as shown in *Figure 26*.

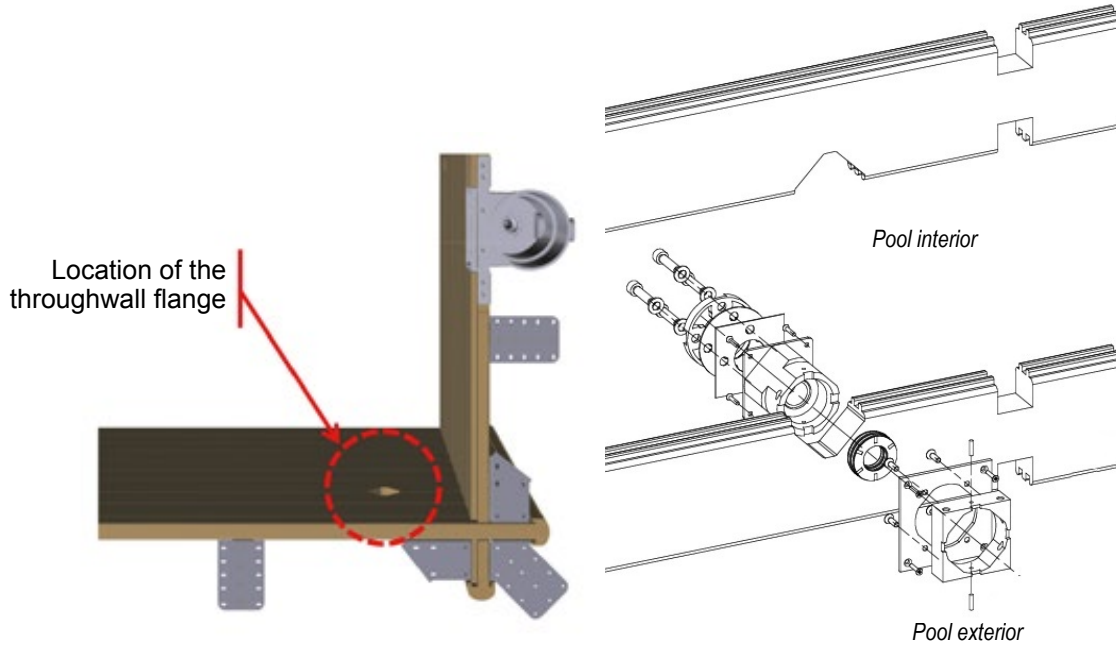

Figure 26 – Location of the throughwall flange

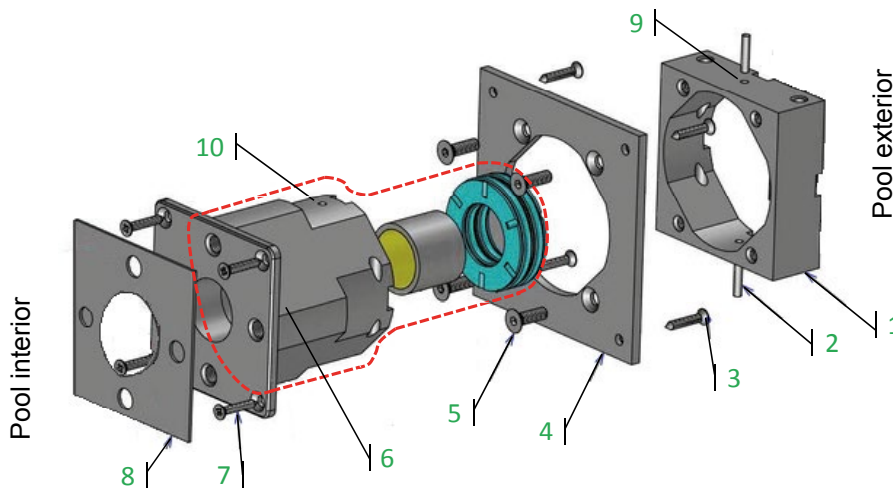

Figure 27 – Mounting the throughwall flange

Assembly of the throughwall flange is set out step by step below. The numbers referred to are those highlighted in green in *Figure 27*. The screws are provided in the bag enclosed with the throughwall flange.

Working from inside the pool, put the throughwall flange (6), which is a collection of three parts pre-assembled in the factory. Fasten it to the wooden pool wall using the 4 crosshead countersunk screws 4.2 × 25 A4 SS (7).

Attach part 1 to part 4 using four FHC screws; 6 × 20, A4 SS (5). Working from outside the pool, attach this assembly to part 6, making sure that the holes (10) in part 6 are correctly aligned with the holes (9) in part

1. Insert the two 4 mm diameter, 20 mm long, pins (2) in these holes.

Fasten the assembly formed by parts 1 and 4 to the wooden wall using 4 crosshead countersunk screws 4.2 × 25 A4 SS (3).

Lastly, glue the adhesive gasket (8) to the body of the throughwall flange (6) making sure that holes in the gasket are correctly aligned with the holes in the part. The liner should be fitted within the next 48 hours (step 9). If this is not possible, delay applying the gasket until just before the waterproofing membrane is fitted. The rest of the part (gasket and flange) will be added after the liner is fitted in order to ensure leaktightness at the throughwall flange

7.2 Bearing mounting unit

The purpose of the bearing mounting unit is to hold the axle in the pool wall opposite the motor and allow rotation of the axle.

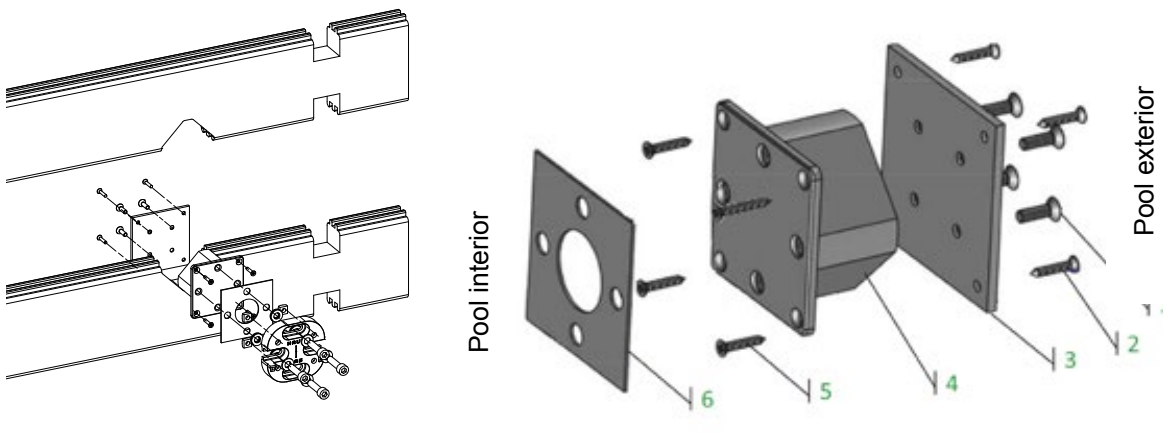

Figure 28 – Mounting the bearing support unit

Assembly of the bearing mounting unit is set out step by step below. The numbers referred to are those highlighted in green in [Figure 28](#). All the screws are provided in the bag enclosed with the throughwall flange.

Working from inside the pool, put the bearing mounting unit (4) in position, fasten it to the wooden wall using 4 crosshead countersunk screws 4.2 × 25 A4 SS (5).

Working from outside the pool, fasten the counter plate (3) to the body of the bearing mounting unit (4) using four socket head countersunk screws 6 × 20 A4 SS (1). Next, screw the counter plate to the wooden wall using 4 crosshead countersunk screws 4.2 × 25 A4 SS (2).

Lastly, glue the adhesive gasket (6) to the body of the bearing mounting unit (4) making sure that holes in the gasket are correctly aligned with the holes in the part. The liner should be fitted within the next 48 hours (Paragraph 9, page 34). If this is not possible, delay applying the gasket until just before the waterproofing membrane is fitted. The rest of the part (flange and gasket washers) will be added after the liner is fitted in order to ensure leaktightness at the bearing mounting unit.

8. IN-POOL LADDER

Assemble the ladder as shown in *Figure 29*. The numbers referred to are those highlighted in green in this diagram.

8.1 Assembling the in-pool ladder

Start by mounting the ABS treads (3) on the aluminium tubes (1) using the 6 aluminium screw, washer and nut assemblies (diameter 8 mm) (12, 13 et 14). Only use aluminium screws, using screws other than aluminium screws could lead to a risk of galvanic corrosion. If necessary, tap the screws (12) in using a mallet or a hammer and martyr block, taking care not to damage the aluminium tube.

Install a ball (2) at each end of the two tubes, then insert the balls on the bottom into the protective bumpers (10), that will allow you to use the ladder without damaging the liner.

Attach the two supports (4) just under the first tread by screwing them to their shells (7) using four A4 SS screws 6 × 40 (9) and washers. Do not over-tighten, the enclosed tube should be able to slide up and down to allow the support to be positioned opposite a full slat and not straddle two wall slats.

8.2 Drilling holes to mount the ladder

Position the ladder in the pool, centring it opposite the wooden access ladder that was assembled previously. The bumpers should rest against the pool floor.

Trace the position of the ladder supports (4) on the pool wall, on a full slat. Remove the ladder and use the gasket (11) to mark the position of the two holes through which the screws (5) will be inserted. Next drill the four 10 mm diameter holes in the pool wall to fasten the ladder in position after the liner has been fitted.

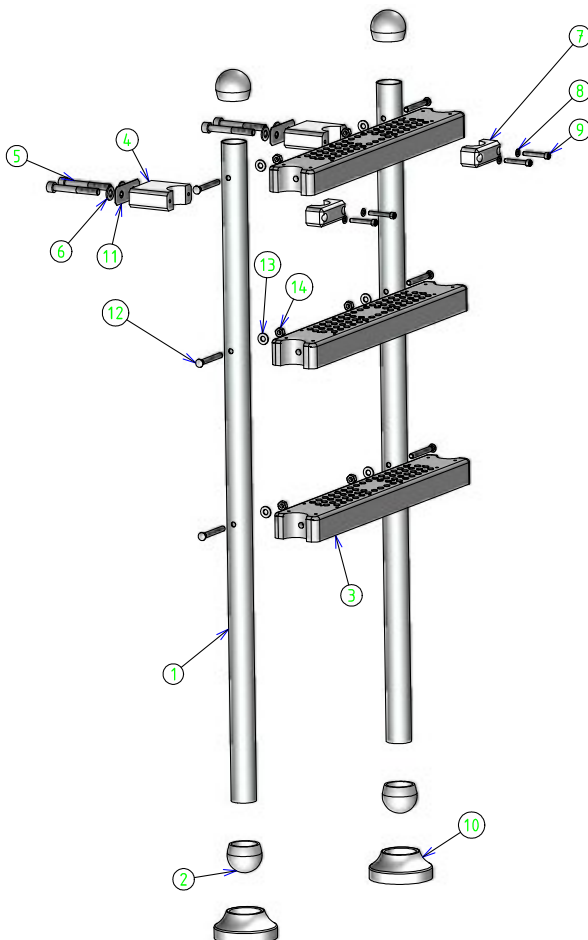

Figure 29 – Assembling the ladder

9. FITTING THE WATERPROOFING MEMBRANE

9.1 Installing the liner locking track

Before starting to install the liner locking track, make sure that the structure has been correctly assembled. To do this, check that the entire periphery is horizontal (use a spirit level), and that the diagonals are equal in length. If not, rectify these imperfections before continuing.

Start installation of the liner locking track in a corner. Continue around the periphery of the pool, taking care with the joints between each 1.18 m length of track. Each section of track must be perfectly aligned with the two adjacent sections of track to avoid damaging the liner. Joints between sections of liner locking track do not need to coincide with the structure's supporting braces.

It may be necessary to trim the track at the end of a length or width: to do this, measure the distance to be covered and cut a bar to that length. Remember to deburr the track after trimming.

The track should be flush with the top of the wooden structure. Before fixing the liner tracking track into position, pre-drill the track using the 4 mm diameter drill bit provided (bag J). Insert the screws provided at approximately 20 cm intervals (countersunk screws 4 × 35, torx, threaded over 20 mm in A4 SS, bag H). Do not overtighten, to prevent screws from passing completely through the rail.

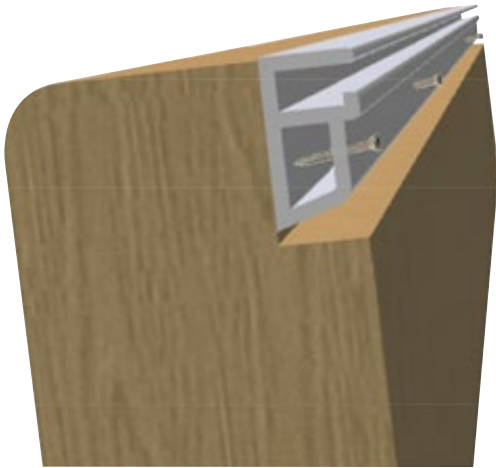

Installing the track

9.2 Drilling for the beam mounting unit

Before fitting the liner, you will need to drill holes to mount the beam on each side of the pool. This beam will support the duckboarding that will cover the area of the pool that contains the automatic cover axle. The beam mounting plate and counter plate are installed after the liner is fitted. Using a 10 mm drill bit, drill blind holes to a depth of about 20 mm.

Position the beam mounting counter plate outside the pool as shown in [Figure 30](#). The top of the counter plate should be flush with the top of the pool wall. Check that the part is correctly positioned vertically and mark the location of the four holes on the wood.

Working from inside the pool, position the counter plate 445 mm from the pool wall, mark the future position of the screws and drill blind holes. The blind holes drilled from inside and outside the pool should meet to form 4 holes.

Repeat this procedure on both sides of the pool.



The holes drilled should be perfectly horizontal and perpendicular to the pool wall to facilitate subsequent insertion of the beam mounting plate screws.

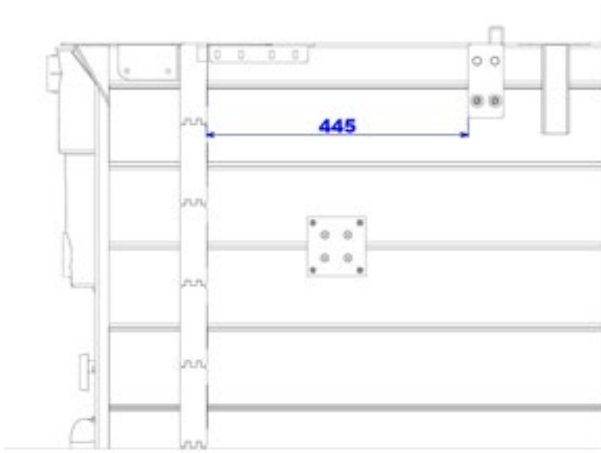

Figure 30 – Position of the beam mounting counter plate

9.3 Applying self-adhesive gaskets

Make sure that the gaskets are correctly positioned and applied. It will be difficult to rectify an omission or mistake after the liner has been fitted. Check that the holes in the various pool fittings (skimmer, throughwall flange, cover bearing mounting unit, etc.) and the holes in the wooden wall are correctly aligned with the holes in the gaskets.

Gaskets should be applied to the following:

- pool fittings (if you did not apply them when installing the part): skimmer and return fitting, throughwall flange and automatic cover axle bearing mounting unit;
- the wooden wall: over the holes drilled to attach the two beam mounting plates (Paragraph 9.2, page 34).and over holes drilled to fasten the ladder (Paragraph 8.2, page 33).

9.4 Fitting the underlay

Before spreading the underlay over the concrete, make sure that the surface of the concrete is smooth, flat and clean.

The underlay is precut to the pool dimensions, no trimming will be necessary. Make sure that the underlay completely covers the bitumous strips. Smooth out crease as much as possible before installing the liner.

9.5 Fitting the liner

- ❗ Before fitting the waterproofing membrane (liner), make sure that the surfaces are free of splinters or any other surface defects that could damage the liner.
- ❗ Ensure that all the gaskets have been correctly applied (Paragraph 9.3 Page 35).
- ❗ The ideal temperature for fitting a liner is between 18 and 25°C.

Put the liner pack in the pool (take care, the liner is very heavy). Remove the liner and unfold it across the pool width (see [Figure 32](#)) then down the length. Before starting to actually fit the liner, allow the liner to rest for a while at ambient temperature (between 18 and 25°C) so that it becomes more supple and easier to fit.

Climb barefoot into the pool, check that the corners of the liner wall are properly aligned with the corners of the pool structure. It is important to spread the liner out properly. Push the liner beading into the liner locking track in the corners and then continue along the pool walls. Use half clothes pegs to block the liner in position as you proceed (not provided), particularly in the corners ([Figure 31](#)).



Figure 31 – Blocking the liner in position using half clothes pegs

Check that the liner is correctly positioned (no excessive stress loading, no creases on the pool floor or walls).

- ! Should the liner need to be repositioned while fitting, never pull it along the track. Release the liner and reposition it to avoid the risk of tearing.



Figure 32 – Unfolding the liner

If there are creases in the pool floor, smooth them out as much as possible before beginning to fill the pool with water. Check that the liner is correctly engaged in the track, particularly in the corners, before filling the pool with water. Continue to check while the pool is filling. Leave the half pegs in place until the pool is filled.

Fill the pool with a few cm of water, and smooth out any creases pushing them from the centre of the pool towards the walls. Once the water is deeper than 10 cm, it will no longer be possible to smooth out creases. Once creases have been smoothed out, continue filling the pool until the water is 45 cm deep, that is 20 cm below the bottom of the return fitting.

- ! Residual creases in the liner caused by folding it are normal and will disappear over time.

9.6 Underwater light cable ties

In the middle of the pool width, on the cover side, glue two adhesive mounts to the liner (Figure 32), they should be vertically aligned and 70 cm apart, the top one being glued approximately 3 cm from the top of the pool wall. These ties will be used to hold a tube, diameter 16 mm, through which the underwater light power cable will be run.



Figure 33 – Adhesive mounts to hold the cable ties

9.7 Installing flanges on pool fittings

Before continuing to fill the pool, install flanges on the following pool fittings in order:

- the return fitting (when the water level is 20 cm below the return fitting)
- the throughwall flange and the automatic cover axle bearing mounting unit (when the water level is 5 cm under the part to which the flange is to be applied)
- the skimmer (when the water level is 5 cm under the skimmer)

Installation of the flanges and their gaskets is described step by step in the following four paragraphs.

TIP: Recommendations apply to the installation of all flanges:

- locate the holes in the pool fitting underneath the liner and mark them with a pen,
- check that the marks line up with the holes in the corresponding gasket by holding the gasket over them,
- tighten the various flange screws alternately in order to ensure a leaktight fit,
- tighten by hand, applying too much torque could split the flange,
- using a Stanley knife, cut away the liner inside the flange.



Check for leaks while the pool is filling. The water level in the pool should be as shown in [Figure 48](#) Paragraph 10.5, page 45.

If while filling the pool, the liner comes away from the track, stop filling the pool before reengaging it. Depending on the depth of water in the pool, it may be necessary to partially empty the pool before reengaging the liner.

9.7.1 Return fitting flange

The procedure to follow for installation of the return fitting flange is illustrated in [Figure 34](#) :

- locate and mark the four screw housings underneath the liner. Pierce the liner at the marked positions,
- glue the adhesive gasket to the flange, taking care to ensure that the holes in the gasket line up with the holes in the part,
- screw the flange onto the body of the return fitting using four countersunk screws 5 × 16, A4 SS (enclosed with the return fitting),
- using a Stanley knife, cut away the liner inside the flange,
- lastly, screw the eyeball-union-trim assembly onto the return fitting body.



Figure 34 – Installing the return fitting flange

9.7.2 Throughwall fitting flange

The procedure to follow for installation of the throughwall fitting flange is illustrated in [Figure 35](#) (in this figure, the liner is sandwiched between parts 4 and 5) :

- locate the positions of the four throughwall fitting (5) holes underneath the liner and mark them. Pierce the liner at the marked positions;
- glue the adhesive gasket (4) onto the flange (3), taking care to ensure that the holes in the gasket and the part are correctly aligned;
- screw the gasket (3) onto the return fitting body (5) using four socket head cap screws, 10 × 40, A4 SS (1) equipped with 4 washers(2). The screws and washers are provided in the bag of screws enclosed with the throughwall fitting;
- using a Stanley knife, cut away the liner inside the flange.

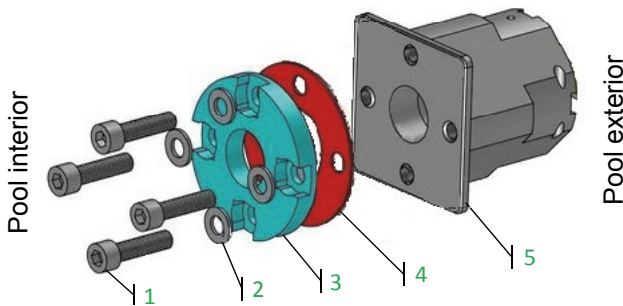

Figure 35 – Mounting the throughwall fitting flange

9.7.3 Bearing mounting unit flange

The procedure to follow for installation of the bearing mounting unit is illustrated in [Figure 36](#) (in this figure, the liner is sandwiched between parts 4 and 5) :

- locate the positions of the four holes in the bearing (5) underneath the liner and mark them; using a pointed object pierce the liner in the centre of each screw housing;
- assemble in order: the four socket head cap screws, 10 × 40, A4 SS (1) with four A4 SS washers, diameter 10 mm (2), the bearing mounting unit flange (2), the other four A4 SS washers, diameter 10 mm, then the rubber washers (4). Screw this assembly onto the bearing mounting unit. The screws and washers are provided in the bag of screws enclosed with the bearing mounting unit.
- adjust the horizontal position of the bearing mounting unit flange before tightening completely, such that the central vertical mark is the same distance from the width wall as the throughwall flange shaft on the motor side.

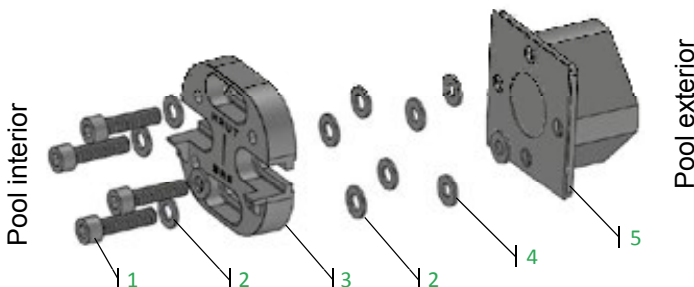

Figure 36 – Assembly of the bearing mounting unit

9.7.4 Skimmer flange

The procedure to follow for installation of the skimmer flange is illustrated in [Figure 37](#):

- glue the second gasket onto the inner surface of the skimmer flange;
- locate the 4 holes in the corners of the skimmer underneath the liner and mark them;

- screw the flange onto the skimmer through the 4 corner holes. Proceed fastening the skimmer in place using the 18 countersunk screws, 5.5 × 25, A4 SS, tighten the screws alternately (provided in the bag enclosed with the skimmer);
- using a Stanley knife, cut away the liner inside the skimmer. Keep the liner cut outs for future repairs.

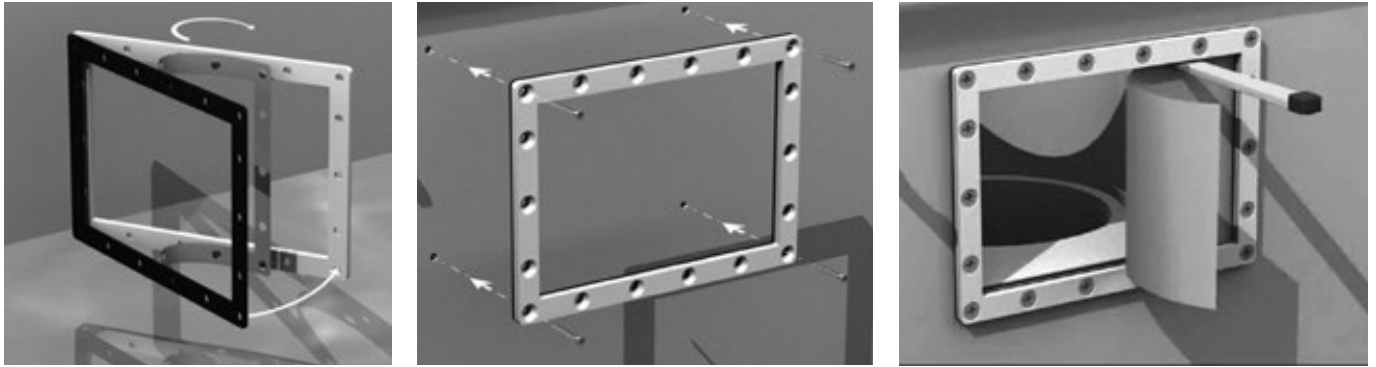

Figure 37 – Mounting the skimmer flange

Next, install the skimmer weir, smooth side facing towards the pool, by pushing the tabs into the notches provided for that purpose in the bottom of the skimmer. The weir should swing freely, however it should not be able to swing out over the pool (the stopper at the top of the skimmer should prevent this). Lastly, clip on the skimmer face plate.

9.8 Installation of the ladder rails

Glue the two remaining gaskets onto the ladder supports (part no. 4 in [Figure 28](#))

Install the ladder in the pool, fix it in position by inserting the 4 socket head cap screws, 10 x 80, A4 SS (5) into the two supports (4). Finish assembly started in paragraph 8.1, tightening the supports (4) in their shells (7).

10. ASSEMBLY OF THE AUTOMATIC COVER

10.1 ASSEMBLY OF THE AUTOMATIC COVER

10.1.1 Installation of the stainless steel shaft

Working from inside the pool, push the stainless steel shaft into the throughwall flange: the rounded end of the shaft should be outside the pool, while the square end of the shaft should be located inside the pool (*Figure 38*). Push the axle until it is flush with the throughwall flange.

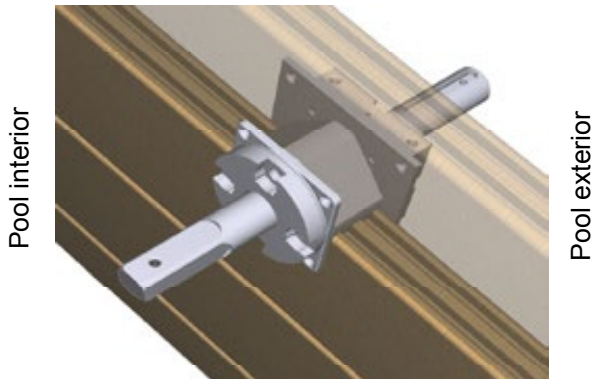

Figure 38 – Mounting the automatic cover shaft

10.1.2 Fitting the axle into the bearing mounting unit

Fit the automatic cover axle into the bearing mounting unit flange (*Figure 39*).

Loosely fasten the axle to the mounting unit using four hex head socket screws 8 × 35, A4 SS, and four washers, diameter 8 mm. Do not tighten the screws: you may adjust the position the bearing in the mounting unit to ensure that the cover axle is perfectly level.

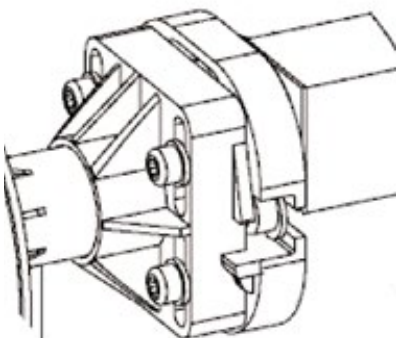

Figure 39 – Fitting the axle into the bearing mounting unit

10.1.3 Fitting the automatic cover shaft into the axle

Push the shaft (previously inserted into the throughwall fitting) into the axle using a mallet. Do not use a hammer. Push it through until the hole in the shaft is facing the hole in the cover axle.

Lock the shaft in position in the axle (*Figure 40*) using a plastic cannula, a 8 mm diameter washer and a socket head cap screw 8 × 65, A4 SS (enclosed with the automatic cover axle).

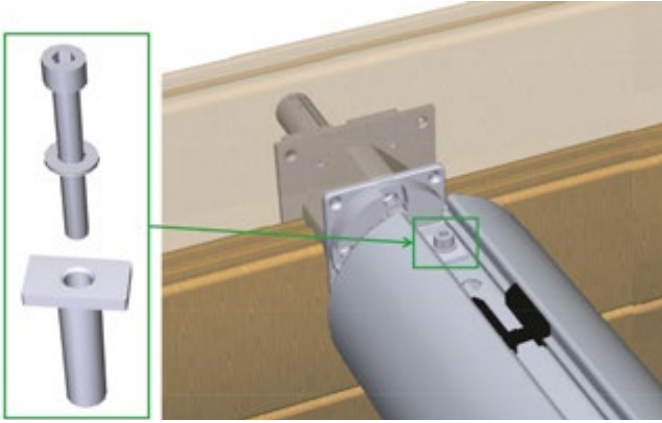

Figure 40 – Locking the shaft in the automatic cover axle

Level the axle: using a spirit level placed on the cover axle, adjust the position of the bearing in its mounting unit as required using the 4 screws fastening the bearing to the bearing support mounting unit flange (see [Figure 39](#)). Once the axle is perfectly horizontal, lock the four screws in position.

Lastly, remove the protective pin (piece of white plastic) from the end of the shaft located outside the pool.

10.2 Beam and beam flanges

The beam assembly steps are illustrated in [Figure 41](#). The screws required for assembly are enclosed in bag Y. In this figure, the wooden wall is located between parts 7 and 8, and the liner is sandwiched between the two rubber gaskets (7).

Fasten the polyamide blocks (2) to the beam mounting brackets (5) using four countersunk screws (6) 4.2 × 19, A4 SS (bag Y), making sure that:

- the polyamide blocks are mounted on the side of the mounting plate to which the threaded rods are welded;
- the brass inserts on the polyamide blocks should be oriented opposite the mounting plate.

Insert the blocks (2) into each end of the beam (1) using a mallet.

Fasten the two pit wall mounting brackets (12) to the beam mounting plates (5) using four screws (14) and four 8 mm diameter A4 SS washers (13). The protruding parts of the pit wall mounting brackets (12) that feature a slot should be located on the same side of the beam (see the zoom in [Figure 41](#)).

Glue the remaining self-adhesive gaskets (7) to the beam mounting plates (5), the other two should have been glued to the wood before fitting the liner.

Install the beam on the pool, taking care to ensure that the protruding parts of the pit wall mounting brackets (12) that feature a slot are facing away from the skimmer and the automatic cover axle.

Working from outside the pool, fasten the beam to the outside of the pool using four hex head 8 × 120, A2 SS screws (9), inserted through the counter-plate (8) placed against the outside of the pool wall. Working from inside the pool, insert four mushroom head square neck bolts 8 × 60, A4 SS (3) equipped with rubber o-rings, diameter 8 mm through the various parts and the pool wall, then working from the outside thread A4 SS washers, diameter 8 mm (11) and 8 mm, A4 SS nuts (10) onto these bolts (3).

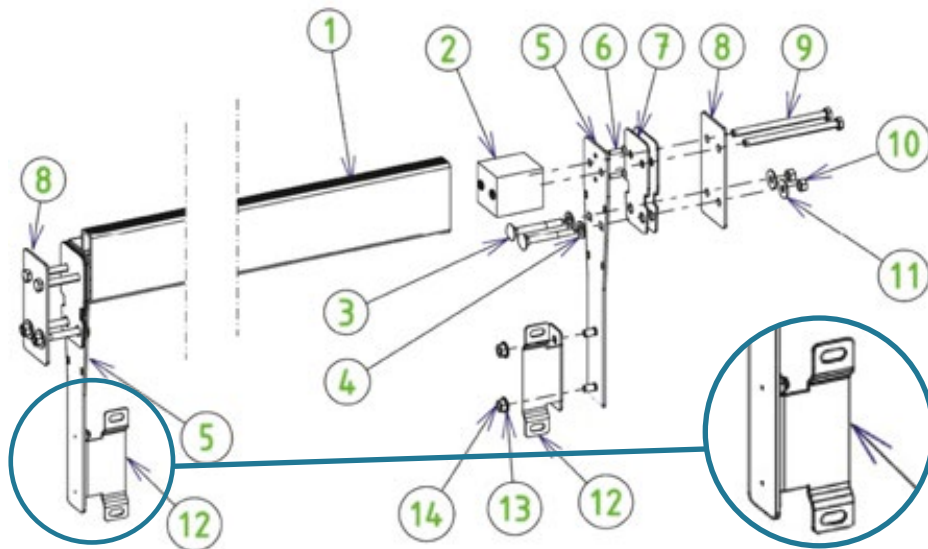

Figure 41 – Assembling and mounting the beam

10.3 Installing the pit wall and the underwater light

As of the 1st of January 2004, the French pool safety standard NF P 90-308 has required that the portion of the pool in which the cover is installed must be separated from the rest of pool. Installation of the pit wall is therefore mandatory.

The pit wall and underwater light assembly steps are illustrated in [Figure 42](#). The screws required for assembly are enclosed in bag Y.

Assemble the two pit wall modules (1) using four hex head 8 × 20 A4 SS screws, and eight 8 mm diameter nuts, place a 8 mm diameter washer on either side of the wall.

Attach two elastic straps (2) to the bottom of the pool wall using two stove screws 8 × 16, A4 SS (3), two washers and two 8 mm diameter nuts. The top of the straps will be subsequently fastened to the wooden duckboarding that covers the part of the pool containing the cover.

Drill a hole, diameter 60 mm, straddling two slats to accommodate the underwater light. Mount the underwater light in this hole, screw the body of the throughwall fitting (5) onto the underwater light (4), then, behind the pit wall screw the nut (6) onto the throughwall fitting body. The underwater light cable should be behind the pit wall.

Fasten the two remaining self-adhesive cable tie mounts ([Figure 33](#)) behind the pit wall: one, a few cm below the underwater light, and the other directly vertically below it, at the bottom of the pit wall. Engage the cable ties in the mounts to hold the underwater light cable in position. Pass the cable through the 16 mm diameter PVC tube and fix this tube in position using the two cable ties inserted into the cable tie mounts previously glued to the liner (Paragraph 9.6, page 31). the cable should protrude from the top of the tube. Leave the cable slack for the time being, you can tension the cable later when the underwater light is fixed in position.

Lastly, fasten the pit wall to the brackets (part 12 in [Figure 42](#)) using four 8 × 16 stove screws (7), four washers and four 8 mm diameter A4 SS nuts.

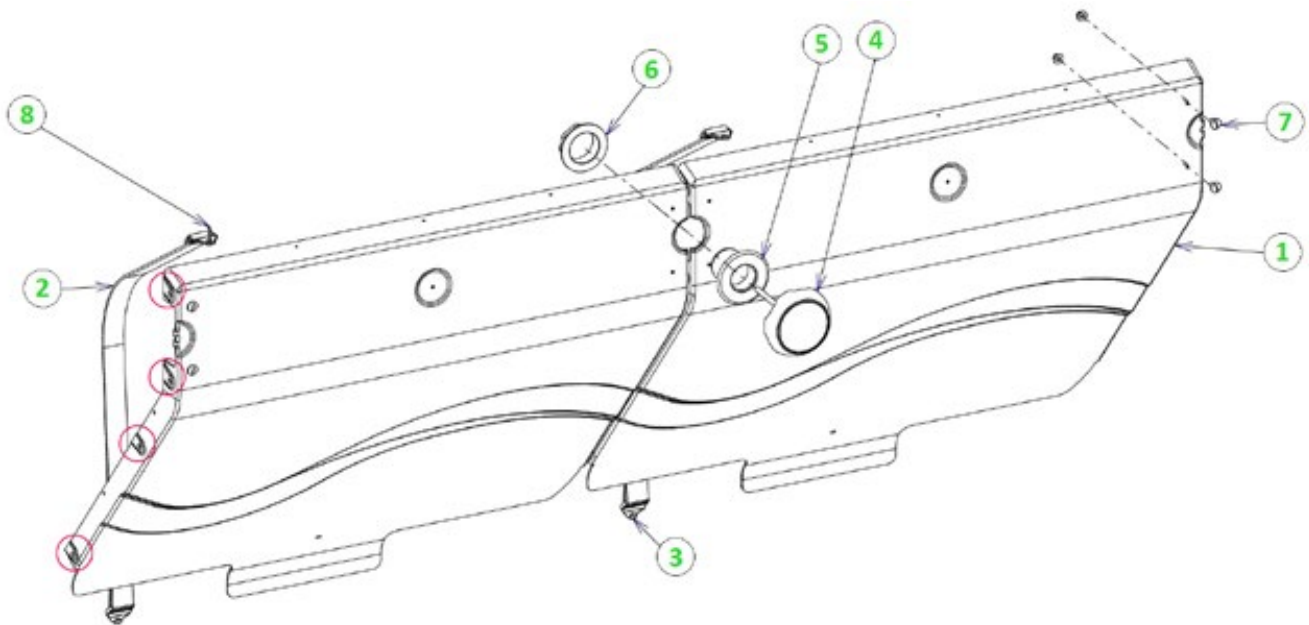

Figure 42 – Installing the pit wall and underwater light

10.4 Automatic cover apron and safety fasteners

10.4.1 Advice prior to installation

Before installing the slat cover apron, make sure that you have the entire cover pre-assembled in modules of 6 slats, the end slat (axle side) holding the straps that fasten the cover apron to the axle, the last two slats (side opposite the axle) that holds the safety straps.

Check that the three U shaped parts that will hold the cover apron fastening straps have been slid into the groove on the axle.

10.4.2 Assembling the slat cover

Assemble the slat module by floating them on the surface of the water and sliding one into the other. The last slat on each module features two notches located 10 cm from each end, these are used to slide in the following slat module.

Store the slats in the shade until just before assembly. If the slats are exposed to sunlight while they are not in contact with the water, they could heat up and be deformed. Slats deformed by heating are not covered within the scope of any guarantee.

10.4.3 Locking the slats in position

Slide one slat module into the other using the notch made in the male part. You may need to bend the slats slightly to slide them together. Slide them together carefully until they are fully engaged ([Figure 43](#)).

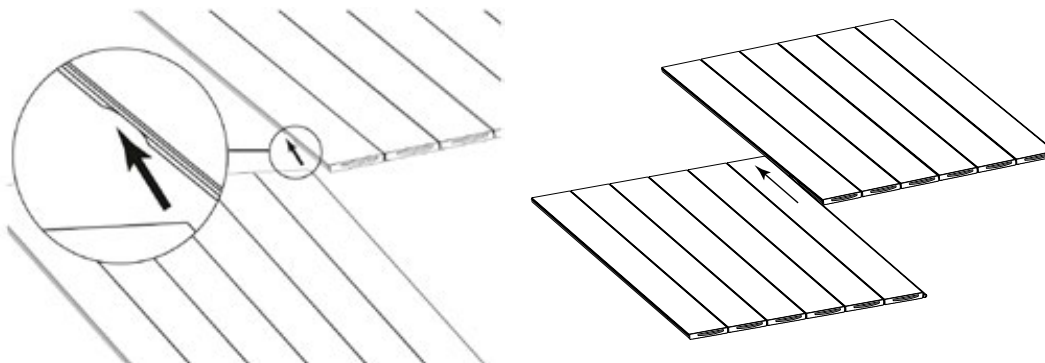

Figure 43 – Assembling the slat cover apron

Holding the slats at a 45° angle, clip in the last few centimetres Use a mallet if necessary ([Figure 44](#)).

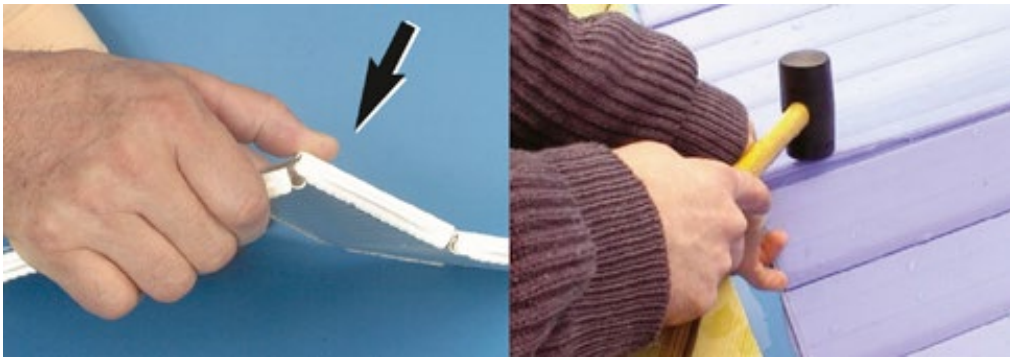

Figure 44 – Clipping the slats together

Once the cover apron is assembled, the tabs on the plugs will prevent the slats sliding from side to side. Fasten the slat on the axle side to the axle as illustrated in [Figure 45](#). The U shaped parts can slide freely so that they can be positioned opposite the straps fastened to the cover slat.

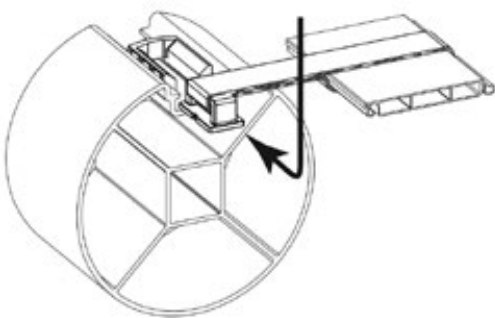

Figure 45 – Fastening the cover to the axle

10.4.4 Installing the cover apron safety fastener

Installation of the safety fasteners is illustrated in [Figure 46](#).

The safety straps (8) are pre-installed on the first two slats of the cover apron. Use the mounting brackets(1) as a drilling template and pre-drill the wall at the locations where the cover safety fasteners will be mounted, that is, the wall opposite the axle, exactly opposite the safety straps. Position the mounting brackets such that the marks N are at the water level (Paragraph 10.5 Page 45).

Fix the mounting brackets (1) to the wall using round head Phillips screws 5.5 × 50 (2) fitted with 6 mm diameter washers (3), after inserting the gasket (4) between the mounting bracket (1) and the liner.

Clip the decorative trim (7) onto the mounting bracket (1) by pressing down hard, and making sure that the stainless steel bar (6) is lowered. Make sure that the trim is fastened on all the way around.

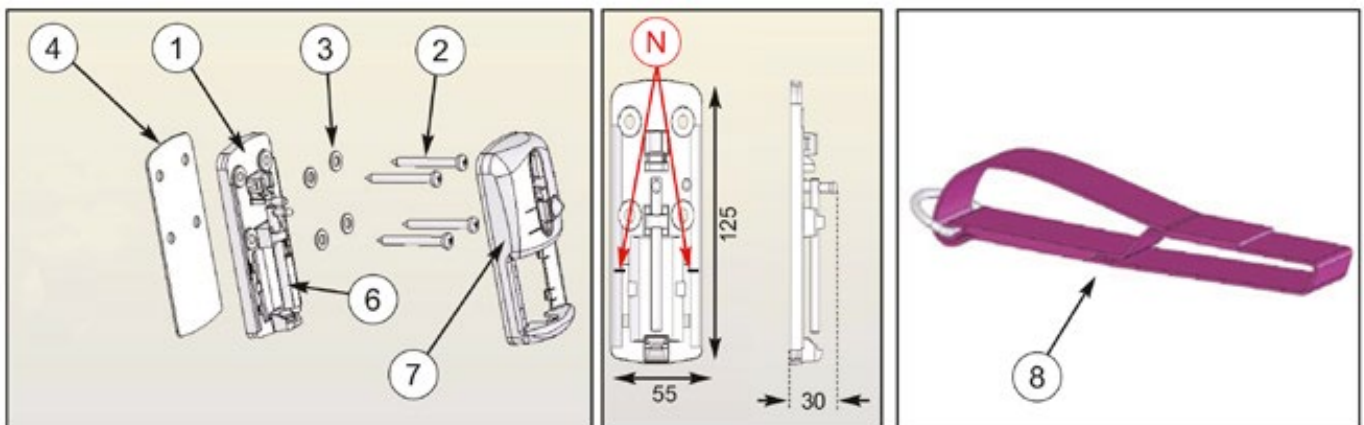

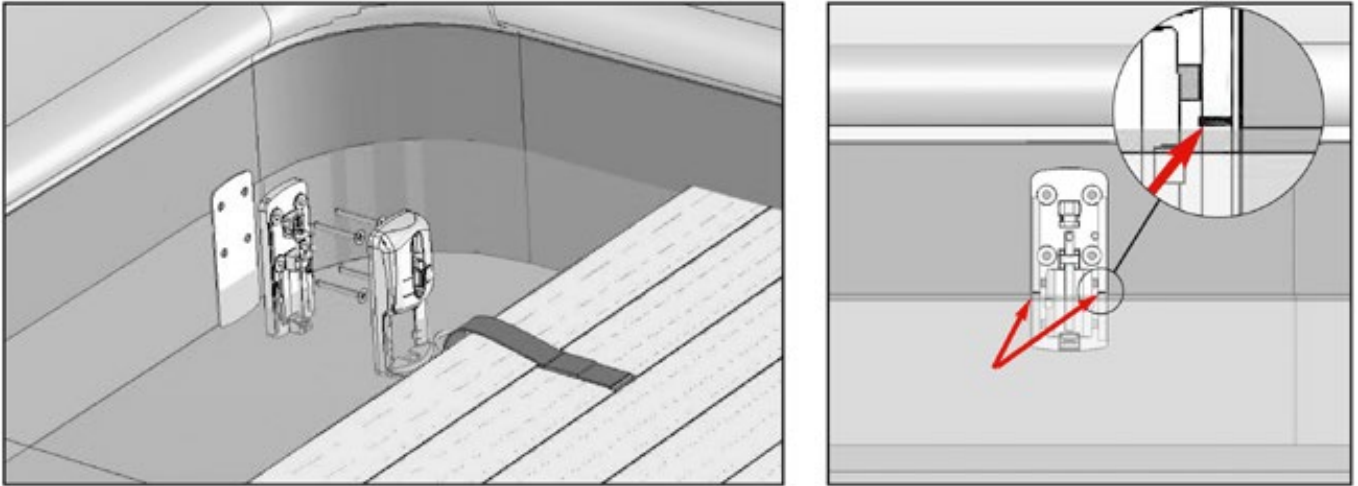

Figure 46 – Mounting the cover fasteners

10.4.5 Securing and releasing the slat cover

To secure the slat cover, roll the cover out over the surface of the water, press the button A, shown in [Figure 47](#) and slide the bar up, then lower it through the ring on the end of the strap. Lower the sliding bar fully to make sure that the strap is secured.

To release the slat cover, press button A and slide the bar up to release the strap ring.

- ❗ The use of fastening straps is mandatory according to French safety standards.
- ❗ Do not forget to release the straps before rolling the cover up: rolling the cover up before releasing the fasteners could lead to significant damage.

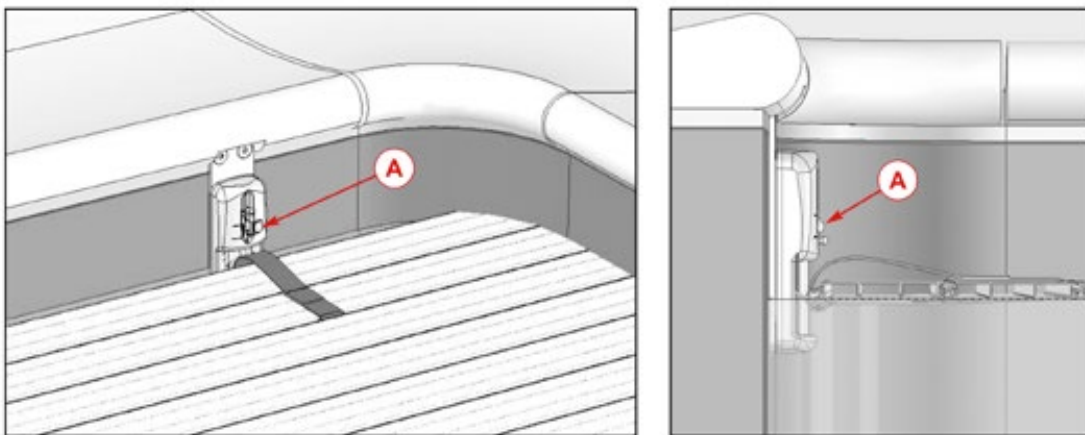

Figure 47 – Securing and releasing the slat apron

10.5 Water level in the pool for correct operation of the cover

As illustrated in [Figure 48](#), the average water depth in the pool (measured from the top of the beam) is 13 cm. The water depth is then 1.2 m with respect to the pool floor.

- ❗ For the automatic cover to operate correctly, make sure that the water level is always between 1.5 cm and 15 cm above the top of the beam. Failure to do so could lead to serious damage to the cover while it is being rolled up or rolled out.

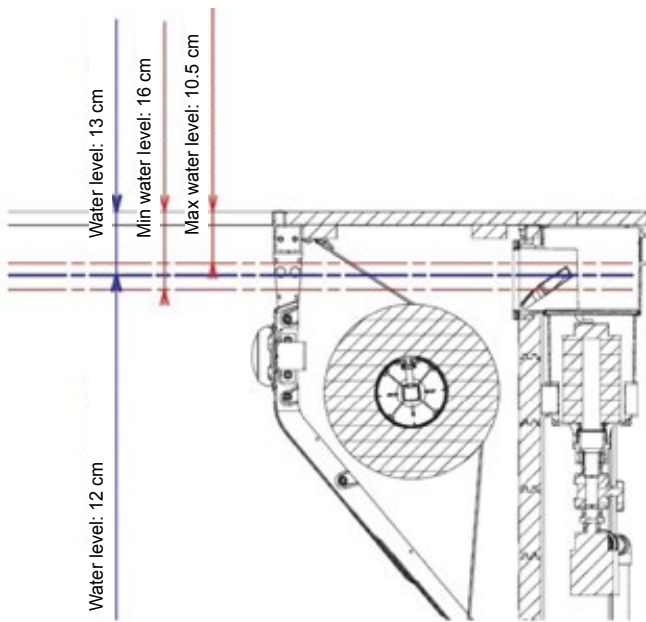

Figure 48 – Water level in the pool

- ⚠ To prevent the water level from rising above the maximum allowed water level, punch out the disk at the back of the skimmer. This hole will act as an overflow for the pool. You may attach a PVC tube to channel overflow water so that it does not run down the skimmer and the pool wall.

11. INSTALLATION OF THE COPING AND FINISHING ELEMENTS

11.1 Cartridge and pre-filter

Screw the filtration cartridge into the skimmer (the cartridge is threaded and the bottom of the skimmer is tapped).

Place a pre-filter on top of the filter. The pre-filter is comprised of a stainless steel ring that is fitted with a filtering pocket made of fabric. Place the pre-filter in the round part of the skimmer.

11.2 Coping

Note the layout of various pool coping modules in [Figure 50](#). Orient them so that the grooved surface is facing up around the periphery of the pool. Allow a 25 mm overhang over the inside the pool (measured from the pool wall). Take the time necessary to ensure that the coping modules are correctly aligned and that the overlap is even. The gap between the interior and exterior modules will vary between 2 and 5 mm.

Coping module no.14 (396 mm long) is installed above the skimmer. This coping module is mounted on a hinge to allow access to the pre-filter and cartridge in the skimmer. Install the two hinges provided between coping modules no. 13 and no.14 and between coping modules no. 14 and no.15 using the holes provided for this purpose before fixing coping modules no. 13 and no. 15 in position, as shown in [Figure 49](#).

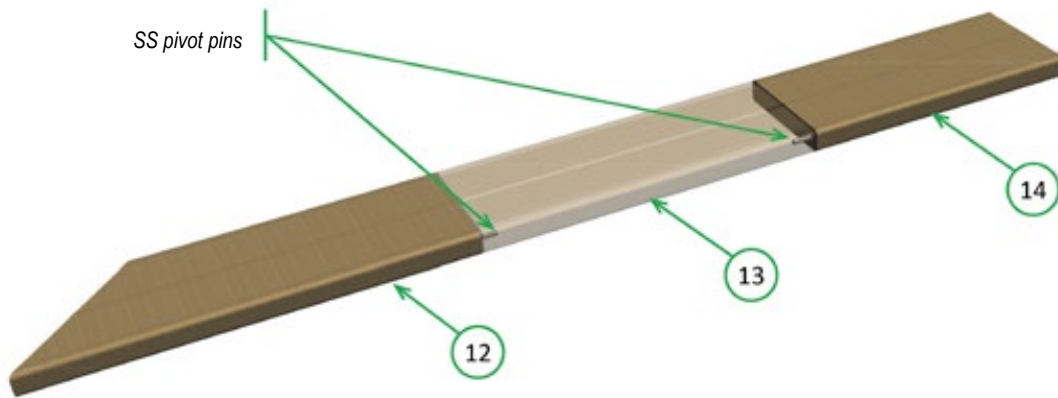
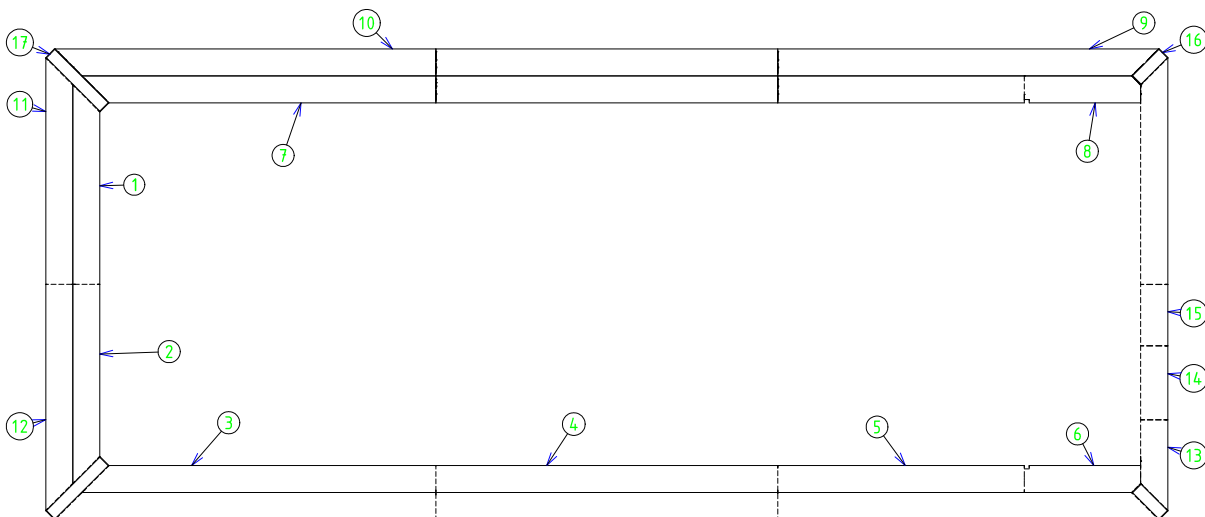

Figure 49 – inserting the pivot pins

Working from underneath, fasten the coping to the metal fittings mounted in the corners and on the supporting braces and to the metal plates mounted on the wooden brackets using torx safety screws 6 × 20, A2 SS (bag G) inserted through the centre of the slots.



NUMBER	QUANTITY	DIMENSIONS (MM)	TYPE
1	1	1071x145	interior
2	1	1071x145	interior
3	1	1901 × 145	interior
4	4	1838x145	interior and exterior
5	2	1325x145	interior
6	1	626 × 145	interior
7	1	1901 × 145	interior
8	1	626x145	interior
9	2	2046 × 145	exterior
10	2	2046 × 145	exterior
11	1	1216x145	exterior
12	2	1216x145	exterior
13	1	485x145	exterior
14	1	329x145	exterior, hinged
15	1	329x145	exterior
16	2	206 × 70	corner
17	2	412 × 70	corner

Figure 50 – Layout of the coping modules

11.3 Duckboarding

Assemble the duckboarding as illustrated in *Figure 51* leave a gap of about 2 mm between neighbouring coping modules. The modules should rest on the pool wall that holds the skimmer and the beam, use:

- 2 cleats, length 735 mm
- 4 cleats, length 585 mm
- 13 coping modules, length 600 mm
- 52 countersunk screws 5 × 40 A4 SS, threaded over 25 mm

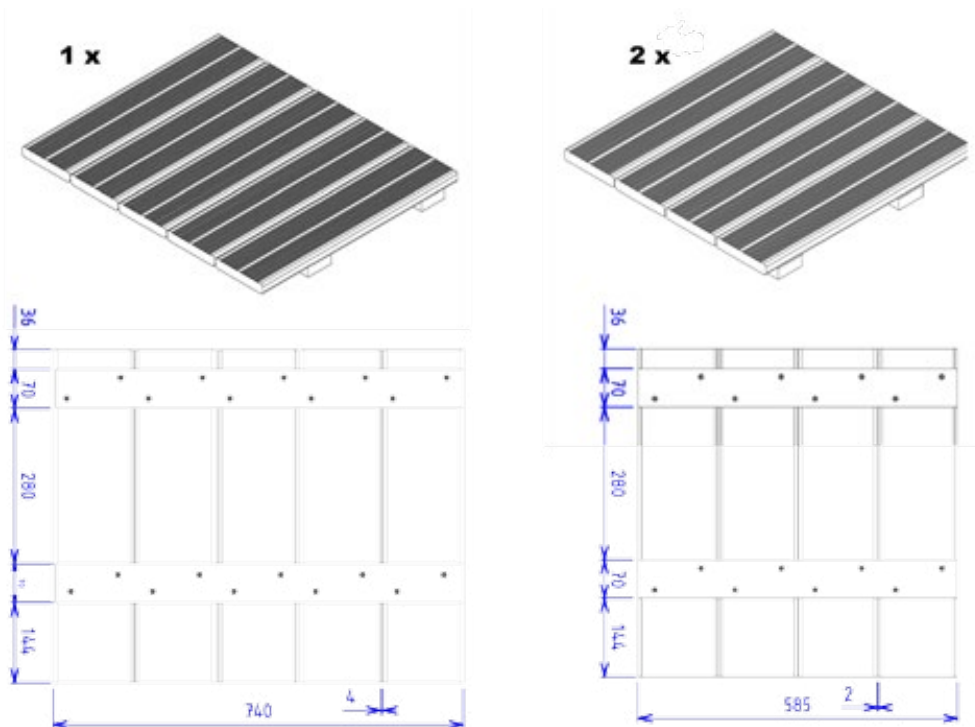

Figure 51 – Assembly of the duckboarding

Put the duckboarding in position (*Figure 51*). Using two hinge screws, 6 × 30, A2 SS, fasten the loops on the elastic straps attached to the pit wall to the underneath of the cleats at a distance of 120 mm from the end of small duckboarding modules. The straps should be parallel to the wall constituting the length of the pool.

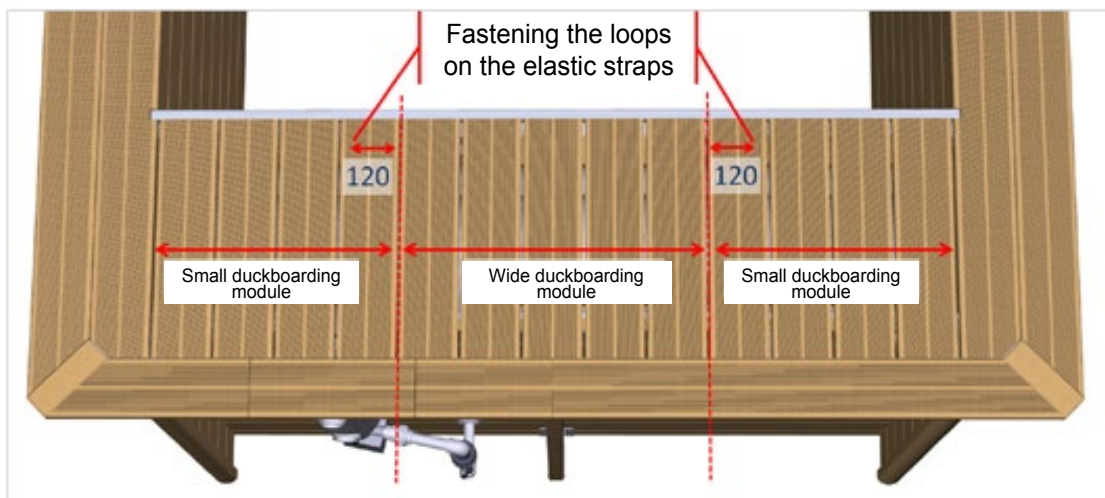

Figure 52 – Fastening the elastic straps underneath the duckboarding

11.4 Ladder hand rail

Drill vertical holes in the coping over the wooden steps at the locations of the 8 holes in the left-hand and right-hand handrail mounting brackets that are also being used to hold the wooden ladder in position. (See *Figure 16 of Paragraph 5.7, page 26*).

Next, fasten the two ladder handrails in position using eight mushroom head screws 8 × 50, A2 SS, fitted with eight washers and eight nuts, diameter 8 mm (the washer and nut of each screw should be located underneath the coping).

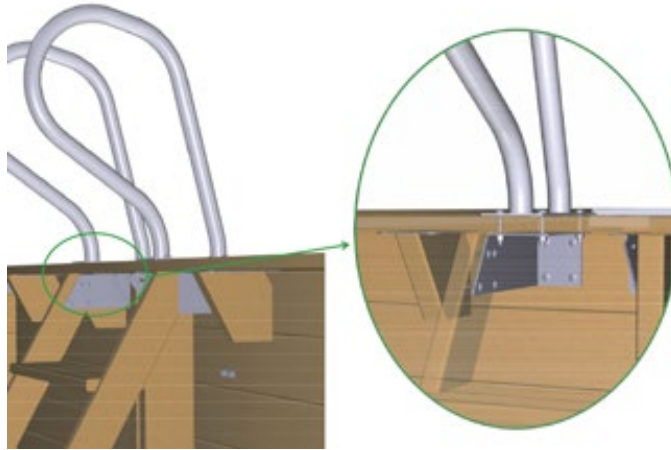

Figure 53 – Mounting the ladder hand rails

11.5 Static swim belt

A static swim belt is enclosed with your pool. To use it, attach it to a coping module far from the automatic cover axle using the 6 mm pop-up bushing enclosed with the belt. Insert the pop-up bushing by drilling a hole, diameter 10 mm, in the coping module selected.



12. WIRING

A wiring diagram for URBAN POOLS is provided in *Figure 54*. The components indicated are necessary for URBAN POOLS to be wired in according to the French safety standard NF C15-100. The pump transformer and the electrical panel should be installed in a place protected against sun and bad weather.

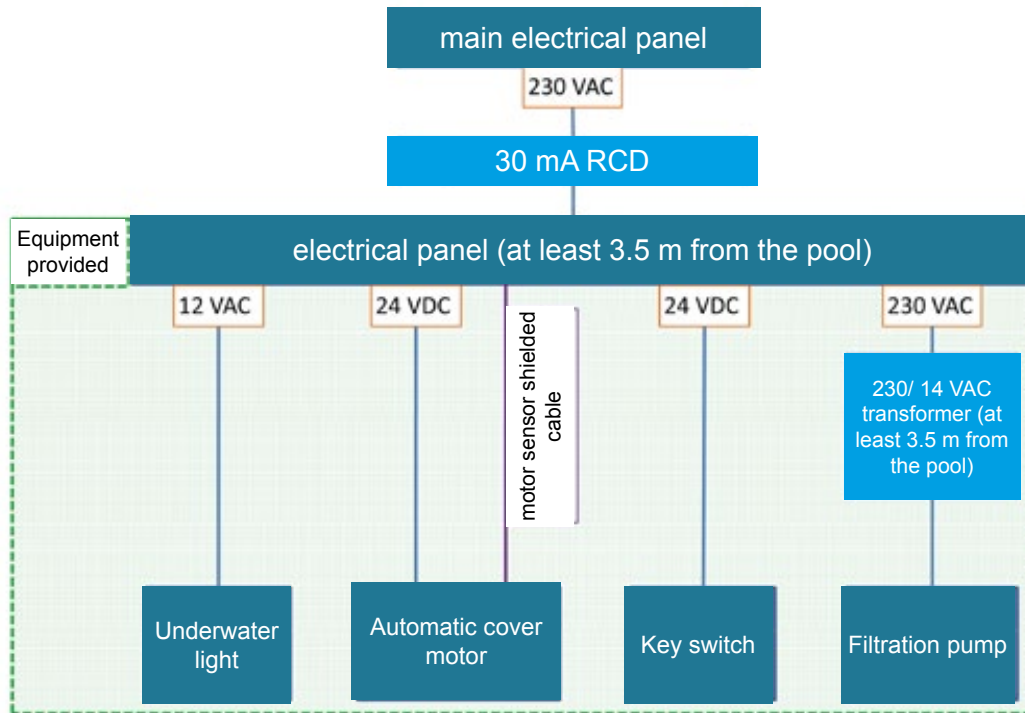

Figure 54 – URBAN POOL wiring diagram

12.1 Automatic cover motor

12.1.1 Safety advice concerning the motor

The URBAN POOL motor is intended for use with URBAN POOL automatic covers. The motor only runs with the electrical panel provided. Operation of the cover without the electrical panel is dangerous and not advised.

The automatic nature of the closing and opening of the cover in no way dispenses the user from exercising proper vigilance while the cover is moving. Should you encounter the slightest problem while rolling the cover out or up, stop the cover (move the key switch to position 0). The key switch should be installed in a location that allows a clear view of the whole pool.

Do not leave the key in the key switch: Store it out of the reach of children each time after you operate the cover (to remove the key, turn the key to position 0)

12.1.2 Assembly of the automatic cover motor

Orient the stainless steel shaft that you previously inserted into the throughwall fitting such that the groove is facing upwards. Slide the water slinger (o-ring) onto the shaft.

Place the motor pin in the groove in the shaft, then install the motor by lining the pin up with the groove. Push it in fully. If you meet resistance, check that the motor pin is correctly positioned.

Put the U-shaped pin in position, making sure that it comes out through the bottom of the lower mounting flange.

12.2 Electrical panel: mounting and wiring

The electrical panel terminals to which you should connect the various components are illustrated in *Figure 55*.

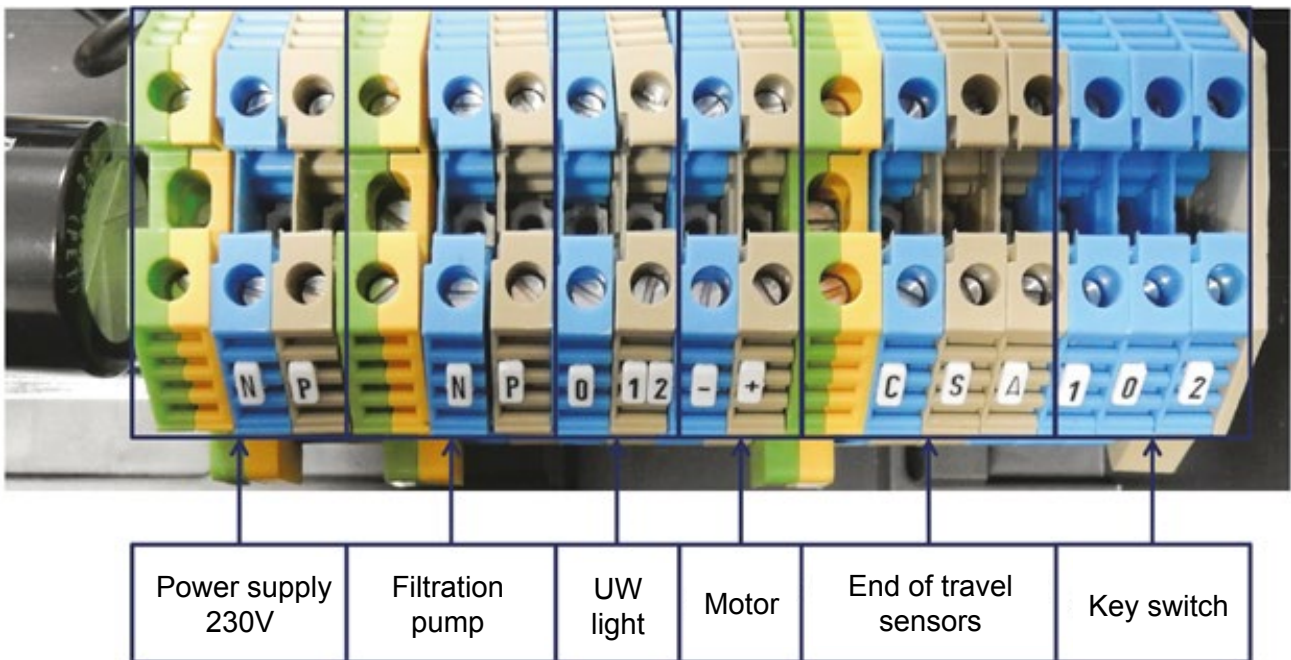

Figure 55 – URBAN POOL electrical panel

12.2.1 Safety advice concerning the electrical panel

The electrical panel must be installed in accordance with the rules of the art and the standards in effect in the country of installation:

- according to the French standard NF C15-100, a 30 mA RCD must be installed at the head of the line;
- prior to any intervention requiring removal of the front face, make sure that power to the electrical panel has been cut;
- if a fuse needs to be replaced, use a fuse with the same rating.

12.2.2 Mounting the electrical panel on the wall

The electrical panel should be mounted on the wall as described in the following four steps:

- Loosen the 6 plastic screws and remove the front plate and remove the front panel;

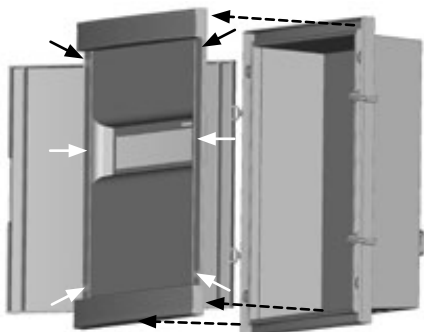

- remove the screw from the mounting bracket at the back of the panel and use the bracket as a drilling template;

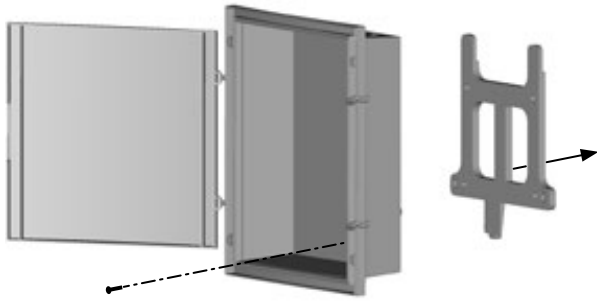

- Fix the bracket to the wall, hang the panel on the bracket and replace the screw to fasten the panel in position;

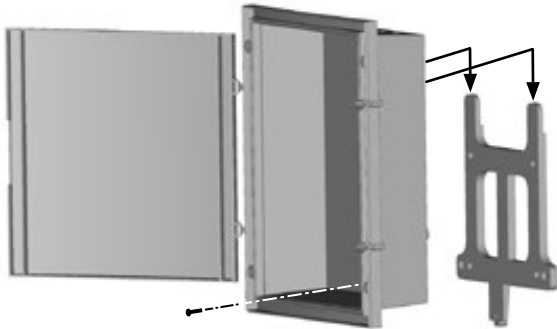

- install the cable glands to allow passage of the cable (one cable per cable gland) and carry out the connections. Tighten the cable gland around the cable to ensure a leaktightness of the connections. Once wiring is complete, replace the front panel.

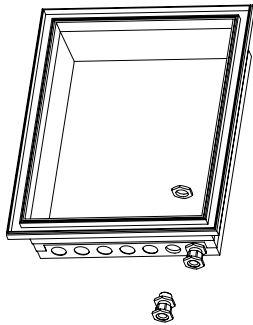

The electrical panel door is reversible. To reverse the opening, start by removing the door, the hinges and the locking mechanism, swap the position of the hinges and the locking mechanism then clip the door into its hinges.

12.2.3 Electrical panel power supply

Connect the 230 V power supply to the N (neutral) and P (phase (live)) terminals at the bottom of the electrical panel and the earth to the yellow and green terminal to the left of the connection terminals (see [Figure 55](#)). The minimum diameter of the power cable wires is 1.5 mm². It may be necessary to increase the wire diameter if the electrical panel is located far from the main panel.

12.2.4 Connecting the filtration pump

Connect the two wires protruding from the pump transformer to the series of N and p terminals second from the left in the electrical panel (see [Figure 55](#)). The wiring polarity is unimportant.

12.2.5 Connecting the underwater light

Connect the two wires from the underwater light to terminals 0 and 12 in the electrical panel (see [Figure 55](#)). The wiring polarity is unimportant.

12.2.6 Connecting the motor

Connect the - and + terminals in the electrical panel (see [Figure 55](#)) to the + terminal (brown wire) and - terminal (blue wire) using the cable connected to the motor. This unshielded cable comprises two wires with a cross section of 2.5 mm².

! The brown wire must be connected to the + terminal, and the blue wire must be connected to the - terminal. A wiring error will reverse rotation of the motor and cause serious damage to the automatic cover.

To extend the cable (if the electrical panel is located more than 3.5 m from the pool), a cable with the same specifications must be used, and wires must be connected via a watertight junction box or using leaktight heat shrink sheaths (one per wire and one for cable itself). The maximum length of the cable between the motor and the electrical panel is 25 m.

12.2.7 Connecting the end of travel sensors

Using the shielded cable that comprises three wires with a cross section of 1 mm² numbered 1 to 3, connect terminals C (Common), S (Signal) and A (Alimentation (power supply)) in the electrical panel (see [Figure 55](#)) to the motor sensor. To do this, connect::

- wire no.1 to terminal A ;
- wire no.2 to terminal S ;
- wire no.3 to terminal C.

The metal braid on the shielded cable should be connected to the earth terminal in the electrical panel (see [Figure 55](#)).

! Wire no.1 must be connected to terminal A, wire no. 2 to terminal S and wire no. 3 to terminal C, failure to wire in the end of travel sensor correctly could result in irreversible damage to the motor sensor.

12.2.8 Connecting the key switch

The location of the key switch must allow an uninterrupted view of the whole pool to ensure that no-one is in the pool while operating the cover. The key switch terminals are numbered 0 to 2 in [Figure 56](#).

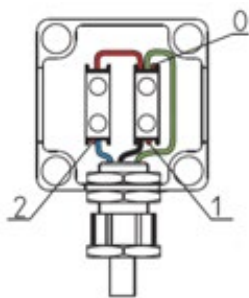

Figure 56 – Key switch

Carry out the following connections using a 3 x 1.5 mm² cable:







- terminal 0 of the electrical panel to the top right of the key switch (terminal 0 – common) ;
- terminal 1 of the electrical panel to the bottom right of the key switch (terminal 1 – open) ;
- terminal 2 of the electrical panel to the bottom left of the key switch (terminal 2 – close),
- to finish, retighten the electrical panel cable gland around the cable.

12.3 Adjusting the ends of travel and anti-tear

This step is carried out using the control pad in the electrical panel. The control pad comprises 3 buttons and 5 LEDs, their functions are described in the following table.

For the first two LEDs, flashing indicates that learning is underway, a steady light indicates that the positions need to be learned (first two LEDs are lit), or that the anti-tear has been tripped (second LED only).

If the 5th LED is lit up, this means that there is a motor sensor signal fault.

						
ends of travel	anti-tear	not used	motor sensor signal	validation of the closed position	validation of the open position	validation of the step carried out

For the initial installation, or when modifying the end of travel settings, start with an initialisation as described in the following three steps:

If the 5 LEDs are off, press the open lock and closed lock keys simultaneously and hold them down for 5 seconds, the 5 LEDs start flashing.

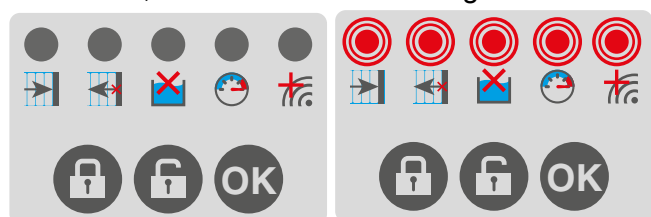

While the 5 LEDs are flashing, press the OK key for 1 second. The two LEDs on the left-hand side light up.

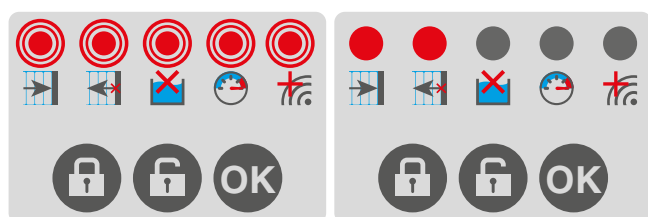

To set the ends of travel and the anti-tear, do the following:

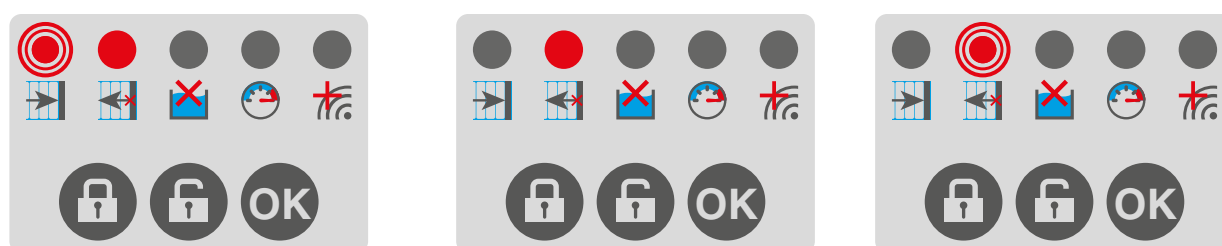

- turn the key to roll out the slat cover until it reaches the side opposite the axle;
- validate the pool closed position by pressing the closed lock key;
- the first LED flashes, the second LED is lit steadily.
- turn the key to roll the cover up over the axle until the first slat is just below the surface of the water;
- validate the pool closed position by pressing the open lock key;
- the first LED flashes, the second LED is lit steadily.
- turn the key and hold it in the close position until the motor stops;
- next, turn the key briefly to the open position; the slatted cover rolls up around the axle and the 2nd LED flashes;
- the 2nd LED goes out 20 seconds after the cover is rolled up.

For safety reasons, contact must be maintained while rolling the cover out over the pool: turn the key to unroll position (pool side), and hold the key in position until the cover stops moving at the previously set closed position.

Contact does not need to be maintained to roll the cover up: to roll the cover up around the axle, turn the key briefly to the open position, the cover will roll up until it reaches the previously set open position.

The following could cause deletion of the end of travel settings:

- power cut while opening or closing the cover;
- power cut while the cover is partially open or closed.

Should this occur, reprogram the ends of travel as described previously.

13. WATER TREATMENT

13.1 Maintaining pool water quality

Correct use of your pool requires optimal water treatment. Be particularly careful to clean the filter cartridge regularly (refer to the cartridge cleaning procedure set out in paragraph 13.3) and make sure that the length of the daily filtration cycle is adequate (see paragraph 13.2).

To fill the pool, use drinking water the properties of which are compatible with the liner. Use of well water or water from a private source is prohibited.

The pool water must be treated regularly in order to maintain water quality. The frequency of treatment will vary depending on the pool's situation, in addition, the user should familiarise themselves with the use of the various products that may be needed to treat the pool and maintain water quality. During the winter season, an algacide and/ or winterizing product may be added to the pool (not supplied).

Test the pool water properties regularly to ensure that they remain within the following limits:

- if the pool is treated with Chlorine, pH between 7.2 and 7.4, free Chlorine concentration between 0.7 and 1.2 mg/L;
- if the pool is treated with Bromine, pH between 7.8 and 8.2, free Chlorine concentration between 1 and 2 mg/L.

The TH (calcium hardness) which measures the calcium hardness of water, that is, the concentration of calcium ions, and the TAC (total alkalinity), that is, the concentration of Hydrogen Carbonate ions, must be between 100 ppm and 250 ppm. A high TAC and/or TH could lead to the deposition of calcium deposits on the liner and on the cover slats, these would be unsightly and could hinder correct articulation of the cover.

Waste water from the pool should be disposed of in accordance with the regulations in effect in the area in which the pool is installed, these may vary.

Furthermore, the user should use only disinfection systems and products compatible with the components constituting the PVC automatic cover, and must comply with the recommendations for use issued by the manufacturers of said systems and products.

13.2 Filtration settings

13.2.1 Length of the filtration cycle

During the pool season, filtration should be run each day long enough to allow all the water in the pool to pass at least three times through the filter within 24 hours, that is, between 10 and 12 hours depending on the cleanliness of the cartridge. For optimal filtration efficiency, filtration should be run during the day, preferably while the pool is in use.

Recommendations based on the water temperature are as follows:

- Below 14°C: 5 to 6 filtration per day.
- Between 15° and 23°C: 6 to 8 hours filtration per day.
- Below 23°C: 10 to 12 hours filtration per day

As the bather load, and the pool water temperature increase, so too should the length of the filtration time. Make sure that the water level in the pool is correct and constant to optimise operation of the filtration system.

13.2.2 Setting the filtration timer

The timer on the front face of the electrical panel is illustrated in *Figure 57*. The numbers shown in green in *Figure 57* are not included on the face of the time to avoid cluttering the dial, but it works similarly to a conventional clock with hands.

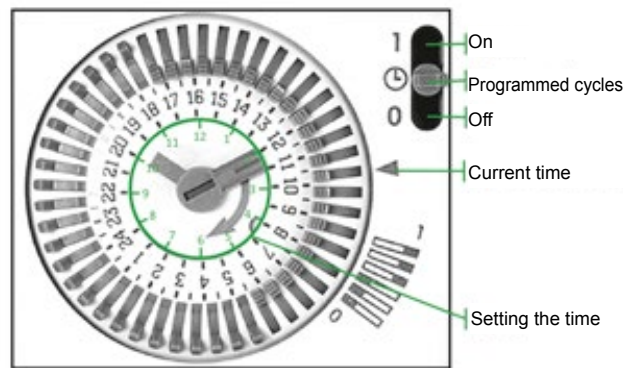

Figure 57 – Front face of the filtration timer

Filtration can be set to run continuously (button at position 1/ On), can be stopped completely (button at position 0/ Off) or can be set to run during programmed cycles (Timer button set to Programmed cycles).

To program the timer, start by setting the time using the small triangular arrow (to the right of the timer) to indicate the current time. Thus, in the example illustrated in *Figure 57*, the position of the hands of the clock could be interpreted as about 10:10 am or 10:10 pm. The time arrow is pointing to the number 10, it is therefore 10:10 am and not 10:10 pm.



Never rotate the dial anti-clockwise.

Next, set the daily filtration cycles. The dial is divided into 48 segments equipped with a mini-lever, each segment represents a 30 minute interval. Push the lever towards the centre so that filtration is stopped during the designated 30 minute interval, towards the outside so that filtration will run during that 30 minute interval. In the example shown in *Figure 57*, filtration will run from 5:30 pm until 5:30 am, and will be stopped between 5:30 am and 5:30 pm.

13.3 Filtration cartridge maintenance

Like all pool filters, dirt will gradually build up on the cartridge as it filters out impurities suspended in the pool water. The more dirty the cartridge is, the less efficient filtration will be. If the bather load is high, the cartridge will need to be cleaned twice a week.

13.3.1 Removal and refitting of the cartridge

- stop the filtration pump and close the suction and return valves to isolate the filter;
- lift up the coping over the skimmer and remove the prefilter and the cartridge;
- clean them (see below);
- screw the cartridge back into the bottom of the skimmer and put the prefilter, fitted with a new sock, back in position;
- open the suction and return valves and restart the filtration pump.

13.3.2 Cleaning the cartridge using a brush and a hose

Clean the cartridge using a hose and a soft bristle brush that reaches between the folds. Cleaning with a hose will remove larger debris (organic debris, hairs). Brushing will remove deposits.

Take care to open out each fold to clean the seams and edges properly. Some hose attachments are specially designed to clean cartridges.

13.3.3 Cleaning the cartridge by soaking

This cleaning method provides a deeper clean of the cartridge. It is possible to buy a ready made cartridge cleaning product, alternatively, make one by dissolving 15 g Sodium Bicarbonate (Sodium Hydrogen carbonate) per litre of water warm water. Leave the cartridge to soak in a bucket of cleaning solution for a few hours, or overnight.

You may also use a solution of approximately 8% acetic acid (pure white vinegar for example) to descale the cartridge.

Caution: Always rinse the cartridge with water before replacing it in the filter.

13.3.4 Replacement of the cartridge

In the event that the cartridge is perforated or significantly deteriorated (dirt that cannot be washed away covering a significant surface area of the filter, growth of bacteria or algae on the cartridge), the filter must be replaced.

14. SAFETY

For your safety, and that of you children, you should read the safety instructions carefully and comply with all points. Safe use of an URBAN POOL requires adherence to all safety instructions set out in this assembly, maintenance and operation manual.

 For the safety of all, always keep the cover closed while the pool is unsupervised, even for a short time, and while the pool is not in use and secure the cover to the safety fasteners at the end of the pool.

14.1 Safety of children

Your URBAN POOL is designed for users aged three years and over. The risk is at its greatest when children are less than 5 years old.



WARNING: Pools can represent a serious danger to small children. Drowning happens very quickly. Children in the vicinity of the pool require constant vigilance and active supervision, even if they know how to swim.

WARNING: The physical presence of a responsible adult is mandatory while the pool is open.

The safety cover is no substitute for good sense or individual responsibility, or for the vigilance of a responsible adult, which remain key in ensuring the safety of young children. Children must not play with the safety cover, nor should the cleaning of the cover be entrusted to children. In the case of a breakdown or malfunction of the cover, or should the cover be temporarily unavailable, take all steps necessary to prevent young children from accessing the pool.

Be careful not to leave toys in or around an unwatched pool, these could attract children. Some equipment, for example an operational proximity or fall detector that is in service, could reinforce the safety of children. However, this type of equipment under no circumstances replaces close supervision.

In the event of an accident:

- get the child out of the water as quickly as possible;
- call the for help immediately and follow the advice given;
- remove the wet clothes and wrap the child in warm blankets

Make sure that there is a telephone (land line or mobile) within easy reach of the pool to avoid leaving the children alone in the event of a problem.

Pool chemicals should be stored out of the reach of children; store them in a safe, inaccessible location. Never leave the cleaning accessories nearby.

14.2 Swimming aids

In the pool, young children and persons who cannot swim must wear a floatation device (vest or arm bands). Do not allow a child who cannot swim enter the pool alone unless wearing a life-vest or armbands. Access to the pool should be strictly prohibited unless these precautions are taken.

14.3 Safety of all users

Safety instructions that apply to all users are as follows:

- do not dive
- do not walk or stand on the coping
- do not leave the pool empty without protection.

Ladders and steps should only be used to enter and leave the swimming pool. They should not be used for any other purpose that could impinge on safety. Before entering the pool, each user should wet the back of his/her neck and his/her arms and legs to avoid thermal shock.

Reinforce supervision when there are several users in the pool. Keep a pole and / or a life ring beside the pool for use in the event of a problem. Jumping should be prohibited, as should running and horseplay.

Keep the water clear and clean during the pool season. Do not allow access to the pool if the filtration system or systems are compromised, or while maintenance is being carried out.

14.4 Safety plate

Attach the safety plate (*Figure 58*) to the pool wall using four zinc plated countersunk head torx screws, 4 x 25 (bag K).



Figure 58 – Safety plates

TIP: Accidents don't just happen to other people, be ready to react! Notably:

- memorise first aid numbers and display them near the pool. 112 in the European Union. Also, display the number of the nearest anti-poison centre at the pool site.
- learn first aid so that you can provide assistance in the event of an accident

14.5 Safety cover

 The physical presence of a responsible adult is mandatory while the pool is open.

The cover can only act as a safety cover (and comply with the French safety standard NF P90 308) if end of the slat cover is fastened to pool wall. Therefore, the cover must systematically be attached to the safety fasteners (Paragraph 10.4 Page 43).

 Safety is only assured if the cover is installed in accordance with the instructions provided in this document and is closed and locked.

Remain vigilant while manipulating the cover. Before running the motor, the person operating the cover must check:

- that there is no-one in the pool and keep watch over the pool while opening or closing the cover;
- that no floating object or automatic cleaner could hinder movement of the slat cover;
- that the water level is constant and complies with manufacturer's recommendations (not too high, not too low), so that the slat cover can pass between the beam and the pit wall (Paragraph 10.5 Page 45).

Watch the cover moving until it reaches its end of travel. The cover must be fully opened or completely closed, never leave the cover in an intermediate position.

Do not stand, walk or jump on the safety cover.

In the event that the automatic safety cover is inoperative, or a malfunction prevents the cover from being closed and secured, or the equipment or the pool is temporarily unavailable, take all measures necessary to deny young children access to the pool until the cover is repaired or normal operating conditions are resumed.

The cover must only be operated by responsible adults. It may be operated by children aged 8 years and over, by persons with mental, physical or sensory disabilities, and by persons with no experience or knowledge, subject to the condition that:

- said persons are correctly supervised;
- said persons have been given instructions concerning the safe use of the cover and the pertaining risks and that they have understood said.

14.6 Filtration pump

If the filtration pump shows any sign of an abnormal leak, stop it immediately by pushing the button in the electrical panel to 0, then disconnect it at its transformer.

Inspect the pump power cable regularly. Do not use the pump if the power cable is damaged. For electrical safety reasons, the cable of this pump cannot be replaced.

Avoid prolonged contact of the filtration pump transformer with water.

Do not expose the pump to temperatures below 0°C.

To avoid damaging the motor, never allow the pump to run dry.

Never pull the pump by its cable. The filtration pump transformer must be installed in a location that is sheltered from the weather

15. MAINTENANCE OF YOUR URBAN POOL

At least twice year (at the beginning and end of the pool season), carry out a careful inspection of those parts of the pool that are essential to safety. Replace any element presenting wear likely to prevent correct installation of the cover. Use original spare parts, or parts that comply with the specifications set out in this document.

At least once a year, check that the electrical contacts of the power cable and the various electrical equipment connection cables are correctly tightened.

15.1 Maintenance of the pool structure

Wood is a living material; changes in humidity and temperature will cause the wood to work and could lead to cracking or splitting. This is a natural phenomenon that in no way impacts the service life of our products.

The autoclave treatment undergone by the wooden elements of this pool complies with the standards in effect and presents absolutely no danger to people or animals coming into contact with it.

Under no circumstances should any product (for example: wood stain, paint, oil, micro porous product, etc.) Inevitably, the wood will become dirty over time. You may clean the wood once a year using a high pressure jet to remove dirt from the pores in the wood.

Adjust the water pressure carefully to avoid damaging the surface treatment, or raising wood fibres. Inspect the wooden structure regularly (particularly the coping and wooden access steps) and remove any splinters that may have appeared.

This pool equipped with its pit wall is not designed to be dismantled.

Check accessible nuts and bolts over the whole structure regularly and carry out any necessary maintenance (tighten, treat rust, etc.)

The liner of the pool should not be subject to aggressions that could impair its leaktightness.

Over the course of its service life, it may be necessary to completely empty the pool. During this operation, take all the measures necessary to avoid dangers (falls, etc.). Avoid prolonging this period beyond 48 hours, in the case of in-ground or partially in-ground installations, pressure exerted by the ground may cause deformation of the structure.

Failure to respect maintenance instructions may entail serious risks to health, especially that of children.

15.2 Maintenance of the filtration pump

To clean the pump, switch it off by moving the button on the timer to 0, then disconnect the pump at the transformer. Close the pump's suction and return valves. Disconnect it from the pool pipework, undo the ring (part no. 3 in [Figure 59](#)) and the ante chamber (part no. 4). Clean the rotor under water, then reassemble the pump in the reverse order.

The build up of calcium deposits on the rotor can increase the noise level of the pump.



Figure 59 – Filtration pump

15.3 Maintenance of the cover

The cover must be cleaned regularly. Organic or vegetable matter left to stagnate on the cover over a prolonged period of time can cause staining of the slat cover that may be permanent.

A deep clean of the cover, at least twice a year, upon opening the pool and winterizing the pool, is recommended. To deep clean the cover, to a high pressure jet of hot water and a descaling product. The cover should only be cleaned using suitable, recommended products. These products should not be abrasive or contain PVC solvents. Failure to respect these instructions will entail the rejection of any resulting guarantee claim.

15.4 Winterizing the pool

The pool must not be left empty over the winter period (or for any prolonged period of time). In fact, the liquid mass plays a dual role, it provides thermal insulation and acts as ballast, holding the liner in place against the pool structure.

Close the valves, remove the filtration pump and part of the pipework by undoing the locking nuts on the valves (downstream for the top valve and upstream from the bottom valve). Store the components removed. In areas susceptible to freezing, screw a winterizing plug (gizmo) into the bottom of the skimmer to absorb the expansion of ice and protect the skimmer. Remove any water treatment products from the skimmer (Chlorine tablets, flocculant, etc.).

Keep the cover closed while the pool is winterized (rolled out over the pool).

TIP: winterizing is not mandatory, especially if the weather is mild with temperatures that remain above 0°C. In this case; maintain the water level in the pool and run filtration 2 to 3 hours per day. Check the water level in the pool regularly. In the case of significant freezing, run the filtration pump at least 30 minutes every two hours.

16. GUARANTEES

Keep the installation and operation instructions, the invoice, proof of purchase and the tracking number that can be found on the packages. The guarantee does not cover:

- natural ageing of the materials (appearance of corrosion, natural deformation of the wood, etc.);
- damage caused by improper handling while assembling or using the accessories (impacts, scratches, etc. that could alter the surface treatments);
- incidents not directly related to the normal use of the pool or its accessories.

The guarantees set out hereinafter cover parts recognised as defective by our services and are limited to the replacement of the part(s) in question. The cost of dismantling and reassembly is not covered.

16.1 Guarantee covering the wooden components

Wooden components are covered by a 10 year guarantee from the manufacturer against insect infestation and rotting (wood is high pressure autoclaved in accordance with the standards in effect).

This guarantee does not cover natural warping of the wood (appearance of cracks, splitting that is no way impacts the mechanical strength of the wood) or colour changes caused by weathering. Similarly excluded are defects caused by improper assembly and/ or storage: warped slats (exposure to sunlight, assembly delayed after undoing the package), as well as slats that were warped or broken due to assembly other than as described in the installation instructions. Furthermore, any wooden component to which a product (wood stain, etc) has been applied will not be covered by this guarantee.

16.2 Guarantee covering accessories

Accessories are guaranteed against manufacturing and/or assembly defects that may interfere with correct operation of the pool, within the scope of the guarantee conditions. Notably, the guarantee conditions stipulate that the user must carry out periodic checks and maintenance necessary for the pool to operate correctly. The successful outcome of any claim will be contingent on strict adherence to the guarantee conditions.

16.2.1 Liner guarantees

SUBJECT AND SCOPE OF THE GUARANTEE	Leaktightness and durability of the weld seams. The guarantee is limited to replacement or repair of the liner recognised as defective without any other damages or interest.
TERM OF THE GUARANTEE AS OF THE DATE OF PURCHASE	10 years against leaks
CONDITIONS GOVERNING ACCEPTANCE OF A CLAIM	Adherence to conditions governing fitting, use and maintenance

Folds that appear after the liner is fitted are not covered in the scope of this guarantee, these could be the result of pool water chemical and physical properties that are outside the acceptable ranges (the water temperature must be below 28°C, the pH must be between 7.2 and 7.6 if the pool is treated with water, or between 7.6 and 8.4 if the pool is treated with Bromine, and the concentration of disinfectant must be within the range recommended by the manufacturer of the water treatment products).

Also excluded from the scope of the guarantee is the appearance of yellow stains or discolouration along the water line. This may be the result of the deposition of organic compounds floating on the surface of the water (sun creams and oils, residue of hydrocarbon combustion or smoke from wood fires). The water line should be cleaned regularly using a suitable product (not provided) and non abrasive sponge. Water with a very high concentration of calcium can also cause this type of staining due to the build up of limescale on the membrane. Hard water with a TH greater than 250 ppm should be treated with a product to eliminate

calcium and suitable for use in pools (not provided). Your water supplier can provide information regarding the hardness of your water.

The following are also excluded from the scope of this guarantee:

- stains caused by the growth of algae and micro-organisms: the pool water should be treated regularly with an appropriate dose of a suitable disinfectant and algicide ;
- stains, discolouration and wrinkles caused by direct contact with solid oxidising products in direct contact with the membrane (thrown directly into the pool) or pockets of excessively high concentrations of oxidising agents (Frequently associated with failure to run filtration during the dissolution phase);
- stains caused by stagnation and/or decomposition of a foreign body in contact with the liner (dead leaves, oxidisable metallic objects, miscellaneous detritus, etc.);
- damage caused by direct contact with incompatible materials such as bitumen, tar, oils, polystyrene panels, polyurethane. Never apply adhesive tape or glue to the membrane;
- tears in the liner under the hung liner locking track caused by moving the liner without first releasing it from the locking track.

16.2.2 Guarantee covering the standard filtration pump

The following conditions apply to the standard filtration pump, and not the pump supplied with the sand filter (available as an option), that has its own guarantee conditions.

SUBJECT AND SCOPE OF THE GUARANTEE	Operation of the motor
TERM OF THE GUARANTEE AS OF THE DATE OF PURCHASE	2 years
CONDITIONS GOVERNING ACCEPTANCE OF A CLAIM	Regular cleaning of the cartridge Never run the pump dry (in the absence of water)

16.2.3 Guarantee covering ABS fittings (skimmer, return fitting)

SUBJECT AND SCOPE OF THE GUARANTEE	Leaktightness and durability of ABS parts
TERM OF THE GUARANTEE AS OF THE DATE OF PURCHASE	10 years
CONDITIONS GOVERNING ACCEPTANCE OF A CLAIM	Absence of stress-cracking of ABS parts (valves, nuts) caused by surfactants contained in some greases: grease should not be applied to these parts